



City of Lawton

Lawton City Hall
212 SW 9th Street
Lawton, Oklahoma
73501-3944

Lawton Transit Trust Authority

Agenda

Tuesday, March 25, 2025

6:00 PM

Lawton City Hall
Wayne Gilley Auditorium

"Official action can be taken only on items which appear on the agenda. The Authority may adopt, approve, ratify, deny, defer, recommend, or continue any agenda item. The Authority may also propose and enact floor amendments to any matter presented before them. When more information is needed to act on an item, the Authority may refer the matter to the City Manager or the City Attorney. The Authority may also refer items to standing committees of the Council or a board, commission, or authority for additional study. Under certain circumstances, items are deferred to a specific later date or stricken from the agenda entirely."

Roll Call

Consent

The following items are considered to be routine by the Transit Trust and will be enacted with one motion. Should discussion be desired on an item, that item will be removed from the Consent Agenda prior to action and considered separately.

1. Consider approving the Chairman to sign the Authorizing Resolution for FTA that will allow Ryan Landers, General Manager of the Lawton Area Transit Trust, the authority, to the extent set forth in the resolution, to execute and manage all FTA grants that the Transit Trust has approved.
2. Consider approving the Interim City Attorney to sign the Opinion of Counsel for Federal Transit Administration (FTA) acknowledging Ryan Landers' authority to execute all appropriated FTA grants that the Transit Trust have approved and to manage the same.
3. Consider approving a resolution authorizing the filing and execution of a grant for federal assistance under Section 5307 Federal Transit Administration for Federal Fiscal Year 2022 appropriated funding, approving the application, and authorizing the Chairman and Secretary to execute the revised split letter and other associated grant documents.
4. Consider approving a resolution authorizing the filing and execution of a grant for federal assistance under Section 5307 Federal Transit Administration for Federal Fiscal Year 2023 appropriated funding, approving the application, and authorizing the Chairman and Secretary to execute the same.
5. Consider approving a resolution authorizing the filing and execution of a grant for federal assistance under Section 5307 Federal Transit Administration for Federal Fiscal Year 2024 appropriated funding, approving the application, and authorizing the Chairman and Secretary to execute the same.
6. Consider approving a resolution authorizing the filing and execution of a grant for federal

assistance under Section 5339 Federal Transit Administration for Federal Fiscal Year 2022 appropriated funding, approving the application, and authorizing the Chairman and Secretary to execute the same.

7. Consider approving a resolution authorizing the filing and execution of a grant for federal assistance under Section 5339 Federal Transit Administration for Federal Fiscal Year 2023 appropriated funding, approving the application, and authorizing the Chairman and Secretary to execute the same.
8. Consider approving a resolution authorizing the filing and execution of a grant for federal assistance under Section 5339 Federal Transit Administration for Federal Fiscal Year 2024 appropriated funding, approving the application, and authorizing the Chairman and Secretary to execute the same.

Business Items

9. Consider receiving a presentation from Wendel WD Architecture, accepting the thirty percent design for Phase 1 of the Transfer Center, and directing staff to move forward on attaining contract for remaining design and construction bid documents, allowing for floor amendments if necessary.
10. Hold a public hearing and consider approving a resolution updating the Title VI Program for the Lawton Area Transit System (LATS).

Adjournment

The City of Lawton encourages participation from all of its citizens. If participation at any public meeting is not possible due to a disability, notification to the City Clerk at (580) 581-3305 at least 48 hours prior to the scheduled meeting is encouraged to make the necessary accommodations. The City may waive the 48 hour rule if interpreters for the deaf (signing) is not the necessary accommodation."

Item Title:

Consider approving the Chairman to sign the Authorizing Resolution for FTA that will allow Ryan Landers, General Manager of the Lawton Area Transit Trust, the authority, to the extent set forth in the resolution, to execute and manage all FTA grants that the Transit Trust has approved.

Initiator: Christine James, Director

Information Source: Ryan Landers

Background:

The Authorizing Resolution is a resolution or equivalent, from the recipient's Board of Directors or equivalent Authorizing Official, to be responsible for applying for assistance and legally committing the applicant or recipient to compliance with terms of an award of any grant that has been approved by the Transit Trust.

The resolution states Ryan Landers, General Manager of LATS, is authorized to execute appropriated grants for federal assistance that have been presented and approved by City of Lawton Transit Trust with the Federal Transit Administration for federal assistance authorized by 49 U.S.C. Chapter 53, Title 23, United States Code, or other federal statutes authorizing a project administered by the Federal Transit Administration. The Oklahoma Department of Transportation (ODOT), as the designated recipient, has given authority to the City of Lawton Transit Trust, the direct recipient, to apply for Urbanized Area Formula Program assistance.

The resolution also states that Landers is authorized to execute and file with its applications the approved annual certifications and assurances and other documents as approved by the City of Lawton Transit Trust that the Federal Transportation Administration requires before awarding a federal assistance grant or cooperative agreement.

The resolution is necessary for several reasons. First, federal law requires the FTA to have this resolution on file for every grantee of FTA funds. Second, it communicates who the applicant is as well as who the designated recipient is and ensures that the FTA and the applicant, the Lawton Transit Trust, have a clear understanding of that statute. Third, it establishes the legal chain of authority, i.e. that the Trust has received authority from the designated recipient, the Oklahoma Department of Transportation.

The resolution also advises the FTA that there is no threatened litigation or legal impediment to receiving these funds, and that the applicant is legally able to receive federal assistance and how it will use its authority to provide the assistance to serve public transit needs of the community.

Additionally, this is a new required document by FTA for grant execution.

Correlation to the True North Statement:**Exhibit:**

Authorizing Resolution, City Transit Trust Cooperative Agreement, Transit Trust Limited Funding Agreement

Key Issues:

Without this signed document, the City of Lawton will not be able to execute any Federal Transit grants.

Funding Source:

N/A

Staff Recommended Council Action:

Approve the Chairman to sign the Authorizing Resolution for FTA that will allow Ryan Landers the authority, to the extent set forth in the resolution, to execute and manage all FTA grants that the Transit Trust has approved.

ATTACHMENTS:

1. Authorizing Resolution
2. City Transit Trust Cooperation Agreement
3. Transit Trust Limited Funding Agreement

Resolution - No. 2025-__

RESOLUTION AUTHORIZING THE FILING OF APPLICATIONS WITH THE FEDERAL TRANSIT ADMINISTRATION, AN OPERATING ADMINISTRATION OF THE UNITED STATES DEPARTMENT OF TRANSPORTATION, FOR FEDERAL TRANSPORTATION ASSISTANCE AUTHORIZED BY 49 U.S.C. CHAPTER 53; TITLE 23, UNITED STATES CODE, OR OTHER FEDERAL STATUTES ADMINISTERED BY THE FEDERAL TRANSIT ADMINISTRATION.

WHEREAS, the Federal Transit Administrator has been delegated authority to award federal financial assistance for a transportation project;

WHEREAS, the grant or cooperative agreement for federal financial assistance will impose certain obligations upon the applicant, and may require the applicant to provide the local share of the project cost;

WHEREAS, the applicant has or will provide all annual certifications and assurances to the Federal Transit Administration required for the project;

NOW, THEREFORE, BE IT RESOLVED BY **City of Lawton Transit Trust and City of Lawton**

1. That **Ryan Landers, General Manager of the Lawton Area Transit System (LATS)** is authorized to execute any appropriated grants for federal assistance that have been presented and approved by **City of Lawton Transit Trust** with the Federal Transit Administration for federal assistance authorized by 49 U.S.C. Chapter 53, Title 23, United States Code, or other federal statutes authorizing a project administered by the Federal Transit Administration. The Oklahoma Department of Transportation (ODOT), as the designated recipient, has given authority to the City of Lawton Transit Trust, the direct recipient, to apply for Urbanized Area Formula Program assistance.
2. That **Ryan Landers, General Manager of the Lawton Area Transit System (LATS)** is authorized to execute and file with its applications the approved annual certifications and assurances and other documents as approved by the City of Lawton Transit Trust that the Federal Transportation Administration requires before awarding a federal assistance grant.
3. This resolution shall not apply to discretionary grants.

The undersigned duly qualified **Stanley Booker, Chairman of the City of Lawton of Transit Trust** acting on behalf of the **City of Lawton Transit Trust**, certifies that the foregoing is a true and correct copy of a resolution adopted at a legally convened meeting of the Lawton Transit Trust Authority.

PASSED AND APPROVED by the City Transit Trust this 25th day of March, 2025.

Stanley Booker, CHAIRMAN

ATTEST:

Donalynn Blazek-Scherler, SECRETARY

APPROVED as to form this _____ day of _____, 2025.

Timothy Wilson, INTERM CITY ATTORNEY

THE CITY OF LAWTON, OKLAHOMA
AND
THE CITY TRANSIT TRUST
COOPERATIVE AGREEMENT

THIS AGREEMENT is entered into this 25th day of June, 2024, by and between the City of Lawton, Oklahoma, a municipal corporation, (hereinafter “City”) and the City Transit Trust, a public trust (hereinafter “Trust”).

WHEREAS, the City desires to provide public transportation to the citizens of Lawton; and

WHEREAS, the City has determined the Trust is the entity who should be responsible for providing public transportation to the citizens; and

WHEREAS, the City has determined public transportation provides a public benefit to the citizens of Lawton.

NOW, THEREFORE, in consideration of the mutual promises and other good and valuable consideration exchanged herein, the parties hereby acknowledge, understand and agree as follows:

1. TERM OF AGREEMENT.

This agreement shall commence on the 1st day of July, 2024, and remain in effect until the 30th day of June, 2025, unless sooner terminated by mutual agreement of the parties or for cause.

2. TRUST’S SCOPE OF SERVICES

A. The Trust shall, in a professional and competent manner, apply for federal and state funds available for the operation of a public mass transit system.

B. The Trust shall provide at its expense all personnel, equipment, materials and supplies necessary and appropriate to staff and operate the mass transit system. The City shall have no responsibility or liability whatsoever for any wages or benefits earned or accrued by the Trust’s employees or any wages or benefits mandated by federal or state law.

C. The Trust shall also be authorized to place transit system equipment such as signage, benches, shelters, and transfer facilities on any property in which the City has adequate property rights for such placement.

3. MAINTENANCE

The Trust shall be responsible at its own expense for maintenance, upkeep and repair of all elements of the mass transit system.

4. FUNDING BY THE CITY

Without incurring any obligation or liability to furnish a minimum level of funding during any fiscal year while this Agreement is in effect, the City hereby agrees, when the amount of funds available to the City permit, to furnish monetary aid to the Trust to help defray the costs of operating the mass transit system. In addition to any monetary aid the City may provide, the City agrees to furnish minor administrative support to the Trust. Whether adequate funding is available for such purposes will be determined solely by the governing body of the City. Upon a determination that adequate funding is available, the amount of funds to be provided shall likewise be determined solely by the City's governing body as a matter within its sound discretion. The City retains the absolute right to determine funding during any fiscal year irrespective of the level of funding furnished in prior fiscal years. The Trust shall annually submit a proposed budget and request for funding pursuant to the Funding Agreement.

5. INSURANCE

During the term of this Agreement, the Trust shall cause its contractor or subcontractor to provide a policy or policies of public liability insurance insuring the Trust and the City against any and all claims and demands made by any person or persons whomsoever for injuries, damages or losses arising from or in any way connected with the use, operation and maintenance of the transit system. The limits of liability of each policy shall not be less than the maximum limits of liability as provided under the Governmental Tort Claims Act. All policies shall name the Trust and the City, as their respective interests may appear, as the entities insured by such policies and shall provide the City with at least thirty (30) days written notice should the limits be reduced or the policies canceled.

6. INDEMNIFICATION

The Trust shall forever indemnify and hold harmless the City, its officials, agents and employees, from and against all loss, injuries, damage, liability, cost or expense of every kind and nature, including legal fees, arising out of, resulting from or in any way connected with any act, omission or negligence of the Trust or any official, employee, agent, contractor, invitee or visitor of the Trust arising or resulting from the use or operation of the mass transit system.

7. COMPLIANCE WITH LAWS, RULES AND REGULATIONS.

The Trust shall fully comply with all current and future applicable City, State and Federal laws, rules and regulations and all amendments thereto. The Trust agrees to devote special attention to its responsibilities under Federal and State statutes. Observance and compliance with the requirements thereof shall be the responsibility of the Trust without reliance on or direction from the City.

8. REVENUE-GENERATING ACTIVITIES

All revenue derived from the operation of the mass transit system shall be collected by the Trust and expended exclusively for the furtherance and enhancement of the purposes of the mass transit system.

9. TERMINATION OF AGREEMENT

In the event the Trust fails to meet the terms, conditions and covenants of this Agreement or fails to provide the services in accordance with the Agreement, the City may, upon sixty (60) days written notice of default to the Trust, terminate this Agreement. Such termination shall not be an exclusive remedy but shall be in addition to any other rights and remedies the City may have as provided by law.

10. AMENDMENT OF AGREEMENT

No modification, amendment or waiver of any provisions of this Agreement shall be of any force or effect unless in writing and signed by the authorized officials of the parties.

11. VENUE

All material transactions to this Agreement occurred in Comanche County, Oklahoma. This agreement shall be governed by the laws of the State of Oklahoma.

12. SEVERABILITY

In the event any one or more of the provisions contained in this Agreement shall for any reason be held to be invalid, illegal or unenforceable in any respect, such invalidity, illegality or unenforceability shall not affect any other provisions hereof, and this Agreement shall be construed as if such invalid, illegal or unenforceable provision had never been contained herein.

IN WITNESS WHEREOF, the parties have caused this Agreement to be executed by their appropriate officials as of the day and year first above written.

CITY OF LAWTON, OKLAHOMA
A Municipal Corporation

STANLEY BOOKER, MAYOR

ATTEST:

DONALYNN BLAZEK-SCHERLER, CITY CLERK

CITY TRANSIT TRUST
A public trust

STANLEY BOOKER, CHAIRMAN

ATTEST:

DONALYNN BLAZEK-SCHERLER, SECRETARY

APPROVED as to form this 13th day of June, 2024.

For JOHN R. ANDREWS, CITY ATTORNEY

THE CITY OF LAWTON, OKLAHOMA
AND
THE CITY TRANSIT TRUST
AGREEMENT FOR LIMITED FUNDING

This Agreement for Limited Funding is entered into this 25th day of June 2024, by and between the City of Lawton, Oklahoma, a municipal corporation, hereinafter referred to as "City", and the City Transit Trust, a public trust, hereinafter referred to as "Trust".

WHEREAS, the City, by and through its governing body, has determined that the City should provide financial support to the Trust for the operation of a mass transportation service thereby providing a public benefit to the citizens of Lawton; and

NOW, THEREFORE, in consideration of the mutual obligations of the parties, the City and Trust agree as follows:

1. City agrees as follows:

To provide the Trust the sum of one million and four hundred thousand dollars (\$1,400,000) during Fiscal Year 2024-2025 for the operation, management and administration of the mass transit system. Said amounts will be paid to the Trust on an incremental basis upon submission of claims by the Trust to the City. Such claims will be processed by the City and paid to the Trust in accordance with the City's policies and procedures for payment of contractual claims.

2. Trust agrees as follows:

a. To periodically submit to the City's accounting office claims for reimbursement for services performed in the operation, management, and administration of the mass transit system. Such claims will be submitted in accordance with and in compliance with the City's contractual claims policies and procedures.

b. To submit to the Lawton City Council monthly narrative reports which will include the number of riders of the transit system, projects and activities undertaken by the Trust during the reporting period and any other information which may be of interest to the Lawton City Council.

IN WITNESS WHEREOF, the parties have hereunto set their hands on the date and year first above written.

CITY OF LAWTON, OKLAHOMA
A Municipal Corporation

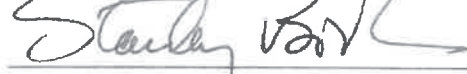

STANLEY BOOKER, MAYOR

ATTEST:



DONALYNN BLAZEK-SCHERLER, CITY CLERK

CITY TRANSIT TRUST
A public trust

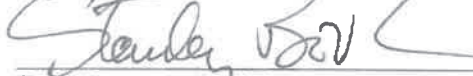

STANLEY BOOKER, CHAIRMAN

ATTEST:



DONALYNN BLAZEK-SCHERLER, SECRETARY

APPROVED as to form for the City of Lawton, Oklahoma, this 13th day of June, 2024.



For JOHN R. ANDREWS, CITY ATTORNEY

Item Title:

Consider approving the Interim City Attorney to sign the Opinion of Counsel for Federal Transit Administration (FTA) acknowledging Ryan Landers’ authority to execute all appropriated FTA grants that the Transit Trust have approved and to manage the same.

Initiator: Christine James, Director

Information Source: Ryan Landers

Background:

The Opinion of Counsel is a legal document that empowers Ryan Landers to carry out the activities specified in the City Transit Trust approved grant award.

The opinion is necessary for several reasons. First, federal law requires the FTA to have this opinion on file for every grantee of FTA funds. Second, it communicates who the applicant is as well as who the designated recipient is and ensures that the FTA and the applicant, the Lawton Transit Trust, have a clear understanding of that statute. Third, it establishes the legal chain of authority, i.e. that the Lawton Transit Trust has received authority from the designated recipient, the Oklahoma Department of Transportation.

The opinion also advises the FTA that there is no threatened litigation or legal impediment to receiving these funds, and that the applicant is legally able to receive federal assistance and how it will use its authority to provide assistance to serve public transit needs of the community.

Additionally, this is a new required document by FTA for grant execution

Correlation to the True North Statement:

Exhibit:

Opinion of Counsel Letter

Key Issues:

Without this signed document, the Lawton Transit Trust will not be able to execute any grants.

Funding Source:

N/A

Staff Recommended Council Action:

Approve the Interim City Attorney to sign the Opinion of Counsel for FTA acknowledging Ryan Landers’ authority to execute all FTA appropriated grants that the Transit Trust have approved and to manage the same.

ATTACHMENTS:

- 1. Opinion of Counsel



OFFICE OF THE CITY ATTORNEY

212 Southwest Ninth Street
Lawton, Oklahoma 73501
Telephone (580) 581-3320
Facsimile (580) 581-3539

March 25, 2025

Ryan Landers
611 SW Bishop Rd.
Lawton, OK 73501

Re: OPINION OF COUNSEL

Dear Ryan Landers:

This communication will serve as the requisite opinion of counsel to be filed with the Federal Transit Administration, United States Department of Transportation, in connection with an application of City of Lawton Transit Trust for federal transportation assistance authorized by 49 U.S.C. Chapter 53; Title 23, United States Code; and other federal statutes authorizing activities administered by the Federal Transit Administration.

The Oklahoma Department of Transportation (ODOT), as the designated recipient, has given authority to the City of Lawton Transit Trust, the direct recipient, to apply for Urbanized Area Formula Program assistance.

Citations to the legal authority of City of Lawton Transit Trust to carry out transportation projects for which federal assistance is sought is set forth below:

1. Pursuant to Resolution No. 2025-___ that **Ryan Landers, General Manager of the Lawton Area Transit System (LATS)** is authorized to execute appropriated grants for federal assistance that have been presented and approved by **the City of Lawton Transit Trust**, with the Federal Transit Administration for federal assistance authorized by 49 U.S.C. Chapter 53, Title 23, United States Code, or other federal statutes authorizing a project administered by the Federal Transit Administration.
2. Allocations in the City of Lawton's annual budget allows for the City of Lawton Transit Trust to provide funds for the local share of a project.

Providing efficient, effective, and responsive service. Promoting a quality of life based on harmony and cooperation. Creating leadership and opportunity for southwest Oklahoma.

3. I have reviewed the pertinent federal, state, and local laws, and I have concluded that for the period of July 1, 2024 through June 30, 2025, pursuant to the annual Cooperative Agreement between the **City of Lawton and the City of Lawton Transit Trust**, there is no legal impediment to your filing an application for a project for which **City of Lawton Transit Trust** seeks assistance. Furthermore, as a result of my examination, I find that there is currently no pending or threatened litigation or other action which might in any way adversely affect a proposed project or the capability of City of Lawton of Transit Trust to carry out a project.
4. This opinion letter shall not apply to discretionary grants.

Sincerely,

Timothy Wilson,
Interim City Attorney

Item Title:

Consider approving a resolution authorizing the filing and execution of a grant for federal assistance under Section 5307 Federal Transit Administration for Federal Fiscal Year 2022 appropriated funding, approving the application, and authorizing the Chairman and Secretary to execute the revised split letter and other associated grant documents.

Initiator: Christine James, Director

Information Source: Ryan Landers

Background:

LATS has prepared a grant application in the amount of \$2,059,318 for transit operations using Federal Fiscal Year 2022 appropriated funding. The local share for this grant is \$1,400,000, which is included in the City of Lawton's FY 2025 budget. The application will be filed and reviewed electronically.

The Urbanized Area Formula Program Grants under 49 U.S.C. Chapter 53, Sections 5307 & 5340 as reauthorized under the Bipartisan Infrastructure Law. The Bipartisan Infrastructure Law, enacted as the Infrastructure Investment and Jobs Act, continues, without change, the Urbanized Area Formula Funding program that makes federal resources available to urbanized areas and governors for transit capital and operating assistance in urbanized areas and for transportation-related planning. An urbanized area is an incorporated area with a population of 50,000 or more that is designated as such by the U.S. Department of Commerce, Bureau of the Census.

Funding is made available to designated recipients that must be public bodies with the legal authority to receive and dispense federal funds. Governors, responsible local officials, and publicly owned operators of transit services are required to designate a recipient to apply for, receive, and dispense funds for urbanized areas pursuant to 49 U.S.C. 5307. The governor or governor's designee is the designated recipient for urbanized areas between 50,000 and 200,000.

Eligible Activities:

The Bipartisan Infrastructure Law continues without change the broad range of activities eligible under the Urbanized Area Formula Program, including:

- Capital projects
- Planning
- Job access and reverse commute projects
- Operating costs of equipment and facilities for use in public transportation (in urbanized areas with a population of fewer than 200,000 individuals)

Eligible activities include planning, engineering design and evaluation of transit projects and other technical transportation-related studies; capital investments in bus and bus-related activities such as replacement of buses and overhaul and rebuilding of buses; crime prevention and security equipment; construction of maintenance and passenger facilities; and capital investments in new and existing fixed guideway systems, including rolling stock, overhaul, and rebuilding of vehicles, track, signals, communications, and computer hardware and software. All preventive

maintenance and some Americans with Disabilities Act complementary paratransit service costs are considered capital costs.

For urbanized areas with populations less than 200,000, costs to operate equipment and facilities for use in public transportation is an eligible expense. In areas with a population greater than or equal to 200,000, operating assistance is an eligible expense for agencies that operate 100 or fewer vehicles in peak service, subject to published limits on expenditures for such expenses. For urbanized areas with populations of 200,000 or greater, funds are apportioned and flow directly to a designated recipient selected locally to apply for and receive federal funds. For urbanized areas under 200,000 in population, the funds are apportioned to the governor of each state for distribution.

The federal share of this grant will be a combination of 50% federal and 50% local for all operating expenses and 80% federal and 20% local for capital expenses such as preventative maintenance, lease, and capital ADA.

Correlation to the True North Statement:

The citizens of Lawton will benefit from the continued funding of the transit system.

Exhibit:

Resolution No. 2025-_____, Revised Split Letter

Key Issues:

Funding Source:

FTA \$2,059,318 and General Fund \$1,400,000

Staff Recommended Council Action:

Approve Resolution No. 2025-_____ authorizing the filing of a grant for federal assistance under Section 5307 Federal Transit Administration for Federal Fiscal Year 2022 appropriated funding, approving the application execution and authorizing the Chairman and Secretary to execute the revised split letter and other associated grant documents.

ATTACHMENTS:

1. 5307 Grant Resolution FY 22
2. Split Letter

RESOLUTION NO. 25-_____

A RESOLUTION AUTHORIZING THE FILING OF A GRANT FOR FEDERAL ASSISTANCE UNDER SECTION 5307, FEDERAL TRANSIT ADMINISTRATION, APPROVING THE APPLICATION FOR PART OF FTA FEDERAL FISCAL YEAR 2022 APPROPRIATED FUNDING AND AUTHORIZING THE CHAIRMAN AND SECRETARY TO EXECUTE APPROVAL OF THE SAME.

WHEREAS, the City Transit Trust is the designated recipient of Urbanized Area Formula Program assistance authorized by 49 U.S.C. Section 5307 Federal Transit Administration (FTA) grants to provide financial assistance in the operation of a public transportation system in the Lawton-Fort Sill community, and

WHEREAS, the City Transit Trust desires to obtain financial assistance from the Federal Transit Administration for the purpose of continuing its public transit system, and

WHEREAS, the City Transit Trust has approved Master Agreement (FTA MA 31) for FTA Federal Fiscal Year 2024, which provides that any entity receiving federal financial assistance must abide by applicable Federal laws and regulations; and

WHEREAS, the City Transit Trust has been previously provided copies of the approved budget and cost allocation plan for this grant.

NOW, THEREFORE, BE IT RESOLVED by the City Transit Trust of Lawton, Oklahoma that:

SECTION 1. The grant application for part of FTA Federal Fiscal Year 2022 appropriated funding under Section 5307, Federal Transit Administration is approved, and the Chairman and Secretary are authorized to execute the same electronically and this instrument shall serve as confirmation of the signatures on the application.

PASSED AND APPROVED by the City Transit Trust this 25th day of March 2025.

STANLEY BOOKER, CHAIRMAN

ATTEST:

DONALYNN BLAZEK-SCHERLER, SECRETARY

APPROVED as to form this _____ day of _____, 2025.

TIMOTHY WILSON, INTERIM CITY ATTORNEY



June 08, 2022

Ms. Gail Lyssy
Deputy Regional Administrator
Federal Transit Administration, Region VI
819 Taylor Street, Room 14A02
Fort Worth, Texas 76102

Dear Ms. Lyssy:

As the Governor’s designee with regard to the administration of Oklahoma’s Section 5307 funds for areas with populations under 200,000, ODOT exercised its rights to delegate the administration of this grant to the City of Lawton Trust recognizing them as direct recipients. This grants them the authority to apply and manage funds attributed to the City of Lawton Trust as outlined below for the associated CARES Act funds:

Small Urban Transit System		
City of Lawton Trust, OK	2022 5307 Funds Apportionment	\$2,059,318.00

As identified in this Split Letter, the Designated Recipient authorizes the assignment/allocation of Section 5307 to the Direct Recipient(s) named herein. The undersigned agree to the Split Letter and the amounts allocated/assigned to each Direct Recipient. Each Direct Recipient is responsible for its application to the Federal Transit Administration to receive Section 5307 funds and assumes the responsibilities associated with any award for these funds.

FOR THE AGENCY: City of Lawton Transit Trust

Stan Booker
Mayor

Date

FOR THE DEPARTMENT: State of Oklahoma Department of Transportation

Jared Schwennesen
Multimodal Division Manager
Office of Mobility & Public Transit

Date

Item Title:

Consider approving a resolution authorizing the filing and execution of a grant for federal assistance under Section 5307 Federal Transit Administration for Federal Fiscal Year 2023 appropriated funding, approving the application, and authorizing the Chairman and Secretary to execute the same.

Initiator: Christine James, Director

Information Source: Ryan Landers

Background:

LATS has prepared a grant application in the amount of \$2,106,449 for transit operations using Federal Fiscal Year 2023 appropriated funding. The local share for this grant is \$1,400,000, which is projected to be in the City of Lawton's FY 25-26 budget. The application will be filed and reviewed electronically.

The Urbanized Area Formula Program Grants under 49 U.S.C. Chapter 53, Sections 5307 & 5340 as reauthorized under the Bipartisan Infrastructure Law. The Bipartisan Infrastructure Law, enacted as the Infrastructure Investment and Jobs Act, continues, without change, the Urbanized Area Formula Funding program that makes federal resources available to urbanized areas and governors for transit capital and operating assistance in urbanized areas and for transportation-related planning. An urbanized area is an incorporated area with a population of 50,000 or more that is designated as such by the U.S. Department of Commerce, Bureau of the Census.

Funding is made available to designated recipients that must be public bodies with the legal authority to receive and dispense federal funds. Governors, responsible local officials, and publicly owned operators of transit services are required to designate a recipient to apply for, receive, and dispense funds for urbanized areas pursuant to 49 U.S.C. 5307. The governor or governor's designee is the designated recipient for urbanized areas between 50,000 and 200,000.

Eligible Activities:

The Bipartisan Infrastructure Law continues without change the broad range of activities eligible under the Urbanized Area Formula Program, including:

- Capital projects
- Planning
- Job access and reverse commute projects
- Operating costs of equipment and facilities for use in public transportation (in urbanized areas with a population of fewer than 200,000 individuals)

Eligible activities include planning, engineering design and evaluation of transit projects and other technical transportation-related studies; capital investments in bus and bus-related activities such as replacement of buses and overhaul and rebuilding of buses; crime prevention and security equipment; construction of maintenance and passenger facilities; and capital investments in new and existing fixed guideway systems, including rolling stock, overhaul, and rebuilding of vehicles, track, signals, communications, and computer hardware and software. All preventive maintenance and some Americans with Disabilities Act complementary paratransit service costs

are considered capital costs.

For urbanized areas with populations less than 200,000, costs to operate equipment and facilities for use in public transportation is an eligible expense. In areas with a population greater than or equal to 200,000, operating assistance is an eligible expense for agencies that operate 100 or fewer vehicles in peak service, subject to published limits on expenditures for such expenses. For urbanized areas with populations of 200,000 or greater, funds are apportioned and flow directly to a designated recipient selected locally to apply for and receive federal funds. For urbanized areas under 200,000 in population, the funds are apportioned to the governor of each state for distribution.

The federal share of this grant will be a combination of 50% federal and 50% local for all operating expenses and 80% federal and 20% local for capital expenses such as preventative maintenance, lease, and capital ADA.

Correlation to the True North Statement:

The citizens of Lawton will benefit from continuing to fund the transit system.

Exhibit:

Resolution No. 2025-_____

Key Issues:

Execution of this grant does not commit the City of Lawton to spending the funds outlined in this agenda. FTA only requires you to have the local match at the time it draws down the federal share to pay eligible costs.

Funding Source:

FTA \$2,106,449 and General Fund \$1,400,000

Staff Recommended Council Action:

Approve Resolution No. 2025-_____ authorizing the filing of a grant for federal assistance under Section 5307 Federal Transit Administration for Federal Fiscal Year 2023 appropriated funding, approving execution of the application and authorizing the Chairman and Secretary to execute the same.

ATTACHMENTS:

1. 5307 Grant resolution fy 23

RESOLUTION NO. 25-_____

A RESOLUTION AUTHORIZING THE FILING OF A GRANT FOR FEDERAL ASSISTANCE UNDER SECTION 5307, FEDERAL TRANSIT ADMINISTRATION, APPROVING THE APPLICATION FOR PART OF FTA FEDERAL FISCAL YEAR 2023 APPROPRIATED FUNDING AND AUTHORIZING THE CHAIRMAN AND SECRETARY TO EXECUTE APPROVAL OF THE SAME.

WHEREAS, the City Transit Trust is the designated recipient of Urbanized Area Formula Program assistance authorized by 49 U.S.C. Section 5307 Federal Transit Administration (FTA) grants to provide financial assistance in the operation of a public transportation system in the Lawton-Fort Sill community, and

WHEREAS, the City Transit Trust desires to obtain financial assistance from the Federal Transit Administration for the purpose of continuing its public transit system, and

WHEREAS, the City Transit Trust has approved Master Agreement (FTA MA 31) for FTA Federal Fiscal Year 2024, which provides that any entity receiving federal financial assistance must abide by applicable Federal laws and regulations; and

WHEREAS, the City Transit Trust has been previously provided copies of the approved budget and cost allocation plan for this grant.

NOW, THEREFORE, BE IT RESOLVED by the City Transit Trust of Lawton, Oklahoma that:

SECTION 1. The grant application for part of FTA Federal Fiscal Year 2023 appropriated funding under Section 5307, Federal Transit Administration is approved, and the Chairman and Secretary are authorized to execute the same electronically and this instrument shall serve as confirmation of the signatures on the application.

PASSED AND APPROVED by the City Transit Trust this 25th day of March 2025.

STANLEY BOOKER, CHAIRMAN

ATTEST:

DONALYNN BLAZEK-SCHERLER, SECRETARY

APPROVED as to form this _____ day of _____, 2025.

TIMOTHY WILSON, INTERIM CITY ATTORNEY

Item Title:

Consider approving a resolution authorizing the filing and execution of a grant for federal assistance under Section 5307 Federal Transit Administration for Federal Fiscal Year 2024 appropriated funding, approving the application, and authorizing the Chairman and Secretary to execute the same.

Initiator: Christine James, Director

Information Source: Ryan Landers

Background:

LATS has prepared a grant application in the amount of \$1,828,974 for the construction of the LATS downtown transfer Center using Federal Fiscal Year 2024 appropriated funding. The local share for this grant is \$454,141, which is projected to be in the City of Lawton’s Capital Improvement Program (CIP) in FY 25-26. The application will be filed and reviewed electronically.

The Urbanized Area Formula Program Grants under 49 U.S.C. Chapter 53, Sections 5307 & 5340 as reauthorized under the Bipartisan Infrastructure Law. The Bipartisan Infrastructure Law, enacted as the Infrastructure Investment and Jobs Act, continues, without change, the Urbanized Area Formula Funding program that makes federal resources available to urbanized areas and governors for transit capital and operating assistance in urbanized areas and for transportation-related planning. An urbanized area is an incorporated area with a population of 50,000 or more that is designated as such by the U.S. Department of Commerce, Bureau of the Census.

Funding is made available to designated recipients that must be public bodies with the legal authority to receive and dispense federal funds. Governors, responsible local officials, and publicly owned operators of transit services are required to designate a recipient to apply for, receive, and dispense funds for urbanized areas pursuant to 49 U.S.C. 5307. The governor or governor’s designee is the designated recipient for urbanized areas between 50,000 and 200,000.

Eligible Activities:

The Bipartisan Infrastructure Law continues without change the broad range of activities eligible under the Urbanized Area Formula Program, including:

- Capital projects
- Planning
- Job access and reverse commute projects
- Operating costs of equipment and facilities for use in public transportation (in urbanized areas with a population of fewer than 200,000 individuals)

Eligible activities include planning, engineering design and evaluation of transit projects and other technical transportation-related studies; capital investments in bus and bus-related activities such as replacement of buses and overhaul and rebuilding of buses; crime prevention and security equipment; construction of maintenance and passenger facilities; and capital investments in new and existing fixed guideway systems, including rolling stock, overhaul, and rebuilding of vehicles, track, signals, communications, and computer hardware and software. All preventive

maintenance and some Americans with Disabilities Act complementary paratransit service costs are considered capital costs.

For urbanized areas with populations less than 200,000, costs to operate equipment and facilities for use in public transportation is an eligible expense. In areas with a population greater than or equal to 200,000, operating assistance is an eligible expense for agencies that operate 100 or fewer vehicles in peak service, subject to published limits on expenditures for such expenses. For urbanized areas with populations of 200,000 or greater, funds are apportioned and flow directly to a designated recipient selected locally to apply for and receive federal funds. For urbanized areas under 200,000 in population, the funds are apportioned to the governor of each state for distribution.

The federal share of eligible capital costs is 80 percent of the net capital project cost, unless the grant recipient requests a lower percentage.

Correlation to the True North Statement:

The citizens of Lawton will benefit from a transit center that provides a safe indoor area to wait for transit.

Exhibit:

Resolution No. 2025-_____

Key Issues:

Execution of this grant does not commit the City of Lawton to spending the funds outlined in this agenda. FTA only requires you to have the local match at the time it draws down the federal share to pay eligible costs.

Funding Source:

FTA \$1,828,974 and CIP \$454,141

Staff Recommended Council Action:

Approve Resolution No. 2025-_____ authorizing the filing of a grant for federal assistance under Section 5307 Federal Transit Administration for Federal Fiscal Year 2024 appropriated funding, approving execution of the application and authorizing the Chairman and Secretary to execute the same.

ATTACHMENTS:

- 1. 5307 Grant resolution FY 24

RESOLUTION NO. 25-_____

A RESOLUTION AUTHORIZING THE FILING OF A GRANT FOR FEDERAL ASSISTANCE UNDER SECTION 5307, FEDERAL TRANSIT ADMINISTRATION, APPROVING THE APPLICATION FOR PART OF FTA FEDERAL FISCAL YEAR 2024 APPROPRIATED FUNDING AND AUTHORIZING THE CHAIRMAN AND SECRETARY TO EXECUTE APPROVAL OF THE SAME.

WHEREAS, the City Transit Trust is the designated recipient of Urbanized Area Formula Program assistance authorized by 49 U.S.C. Section 5307 Federal Transit Administration (FTA) grants to provide financial assistance in the operation of a public transportation system in the Lawton-Fort Sill community, and

WHEREAS, the City Transit Trust desires to obtain financial assistance from the Federal Transit Administration for the purpose of continuing its public transit system, and

WHEREAS, the City Transit Trust has approved Master Agreement (FTA MA 31) for FTA Federal Fiscal Year 2024, which provides that any entity receiving federal financial assistance must abide by applicable Federal laws and regulations; and

WHEREAS, the City Transit Trust has been previously provided copies of the approved budget and cost allocation plan for this grant.

NOW, THEREFORE, BE IT RESOLVED by the City Transit Trust of Lawton, Oklahoma that:

SECTION 1. The grant application for part of FTA Federal Fiscal Year 2024 appropriated funding under Section 5307, Federal Transit Administration is approved, and the Chairman and Secretary are authorized to execute the same electronically and this instrument shall serve as confirmation of the signatures on the application.

PASSED AND APPROVED by the City Transit Trust this 25th day of March 2025.

STANLEY BOOKER, CHAIRMAN

ATTEST:

DONALYNN BLAZEK-SCHERLER, SECRETARY

APPROVED as to form this _____ day of _____, 2025.

TIMOTHY WILSON, INTERIM CITY ATTORNEY

Item Title:

Consider approving a resolution authorizing the filing and execution of a grant for federal assistance under Section 5339 Federal Transit Administration for Federal Fiscal Year 2022 appropriated funding, approving the application, and authorizing the Chairman and Secretary to execute the same.

Initiator: Christine James, Director

Information Source: Ryan Landers

Background:

LATS has prepared a grant application in the amount of \$173,926 for the construction of the LATS downtown transfer Center using Federal Fiscal Year 2022 appropriated funding. The local share for this grant is \$43,527, which is projected to be in the City of Lawton’s Capital Improvement Program (CIP) in FY 25-26. The application will be filed and reviewed electronically.

The Grants for Buses and Bus Facilities Competitive Program (49 U.S.C. 5339(b)) makes federal resources available to states and direct recipients to replace, rehabilitate and purchase buses and related equipment and to construct bus-related facilities, including technological changes or innovations to modify low or no emission vehicles or facilities. Funding is provided through formula allocations and competitive grants.

Eligible applicants for the Buses and Bus Facilities Program include designated recipients that allocate funds to fixed-route bus operators, states (including territories and Washington D.C.) or local governmental entities that operate fixed route bus service, and Indian tribes. Eligible subrecipients include all otherwise eligible applicants and also private nonprofit organizations engaged in public transportation.

The federal share of eligible capital costs is 80 percent of the net capital project cost, unless the grant recipient requests a lower percentage.

Correlation to the True North Statement:

The citizens of Lawton will benefit from a transit center that provides an indoor space to wait for transit.

Exhibit:

Resolution No. 2025-_____

Key Issues:

Execution of this grant does not commit the City of Lawton to spending the funds outlined in this agenda. FTA only requires you to have the local match at the time it draws down the federal share to pay eligible costs.

Funding Source:

FTA \$173,926 and CIP \$43,527

Staff Recommended Council Action:

Approve Resolution No. 2025- authorizing the filing of a grant for federal assistance under Section 5339 Federal Transit Administration for Federal Fiscal Year 2022 appropriated funding, approving the application execution and authorizing the Chairman and Secretary to execute the same.

ATTACHMENTS:

1. 5339 Grant resolution fy 22

RESOLUTION NO. 25-_____

A RESOLUTION AUTHORIZING THE FILING OF A GRANT FOR FEDERAL ASSISTANCE UNDER SECTION 5339, FEDERAL TRANSIT ADMINISTRATION, APPROVING THE APPLICATION FOR PART OF FTA FEDERAL FISCAL YEAR 2022 APPROPRIATED FUNDING AND AUTHORIZING THE CHAIRMAN AND SECRETARY TO EXECUTE APPROVAL OF THE SAME.

WHEREAS, the City Transit Trust is the designated recipient of Urbanized Area Formula Program assistance authorized by 49 U.S.C. Section 5307 Federal Transit Administration (FTA) grants to provide financial assistance in the operation of a public transportation system in the Lawton-Fort Sill community, and

WHEREAS, the City Transit Trust desires to obtain financial assistance from the Federal Transit Administration for the purpose of continuing its public transit system, and

WHEREAS, the City Transit Trust has approved Master Agreement (FTA MA 31) for FTA Federal Fiscal Year 2024, which provides that any entity receiving federal financial assistance must abide by applicable Federal laws and regulations; and

WHEREAS, the City Transit Trust has been previously provided copies of the approved budget and cost allocation plan for this grant.

NOW, THEREFORE, BE IT RESOLVED by the City Transit Trust of Lawton, Oklahoma that:

SECTION 1. The grant application for part of FTA Federal Fiscal Year 2022 appropriated funding under Section 5339, Federal Transit Administration is approved, and the Chairman and Secretary are authorized to execute the same electronically and this instrument shall serve as confirmation of the signatures on the application.

PASSED AND APPROVED by the City Transit Trust this 25th day of March 2025.

STANLEY BOOKER, CHAIRMAN

ATTEST:

DONALYNN BLAZEK-SCHERLER, SECRETARY

APPROVED as to form this _____ day of _____, 2025.

TIMOTHY WILSON, INTERIM CITY ATTORNEY

Item Title:

Consider approving a resolution authorizing the filing and execution of a grant for federal assistance under Section 5339 Federal Transit Administration for Federal Fiscal Year 2023 appropriated funding, approving the application, and authorizing the Chairman and Secretary to execute the same.

Initiator: Christine James, Director

Information Source: Ryan Landers

Background:

LATS has prepared a grant application in the amount of \$179,192 for the construction of the LATS downtown transfer Center using Federal Fiscal Year 2023 appropriated funding. The local share for this grant is \$44,798, which is projected to be in the City of Lawton’s Capital Improvement Program (CIP) in FY 25-26. The application will be filed and reviewed electronically.

The Grants for Buses and Bus Facilities Competitive Program (49 U.S.C. 5339(b)) makes federal resources available to states and direct recipients to replace, rehabilitate and purchase buses and related equipment and to construct bus-related facilities, including technological changes or innovations to modify low or no emission vehicles or facilities. Funding is provided through formula allocations and competitive grants.

Eligible applicants for the Buses and Bus Facilities Program include designated recipients that allocate funds to fixed-route bus operators, states (including territories and Washington D.C.) or local governmental entities that operate fixed route bus service, and Indian tribes. Eligible subrecipients include all otherwise eligible applicants and also private nonprofit organizations engaged in public transportation.

The federal share of eligible capital costs is 80 percent of the net capital project cost, unless the grant recipient requests a lower percentage.

Correlation to the True North Statement:

The citizens of Lawton will benefit from an indoor transit center.

Exhibit:

Resolution No. 2025-_____

Key Issues:

Execution of this grant does not commit the City of Lawton to spending the funds outlined in this agenda. FTA only requires you to have the local match at the time it draws down the federal share to pay eligible costs.

Funding Source:

FTA \$179,192 and CIP \$44,798

Staff Recommended Council Action:

Approve Resolution No. 2025- authorizing the filing of a grant for federal assistance under Section 5339 Federal Transit Administration for Federal Fiscal Year 2023 appropriated funding, approving the application execution and authorizing the Chairman and Secretary to execute the same.

ATTACHMENTS:

1. 5339 Grant resolution fy 23

RESOLUTION NO. 25-_____

A RESOLUTION AUTHORIZING THE FILING OF A GRANT FOR FEDERAL ASSISTANCE UNDER SECTION 5339, FEDERAL TRANSIT ADMINISTRATION, APPROVING THE APPLICATION FOR PART OF FTA FEDERAL FISCAL YEAR 2023 APPROPRIATED FUNDING AND AUTHORIZING THE CHAIRMAN AND SECRETARY TO EXECUTE APPROVAL OF THE SAME.

WHEREAS, the City Transit Trust is the designated recipient of Urbanized Area Formula Program assistance authorized by 49 U.S.C. Section 5307 Federal Transit Administration (FTA) grants to provide financial assistance in the operation of a public transportation system in the Lawton-Fort Sill community, and

WHEREAS, the City Transit Trust desires to obtain financial assistance from the Federal Transit Administration for the purpose of continuing its public transit system, and

WHEREAS, the City Transit Trust has approved Master Agreement (FTA MA 31) for FTA Federal Fiscal Year 2024, which provides that any entity receiving federal financial assistance must abide by applicable Federal laws and regulations; and

WHEREAS, the City Transit Trust has been previously provided copies of the approved budget and cost allocation plan for this grant.

NOW, THEREFORE, BE IT RESOLVED by the City Transit Trust of Lawton, Oklahoma that:

SECTION 1. The grant application for part of FTA Federal Fiscal Year 2023 appropriated funding under Section 5339, Federal Transit Administration is approved, and the Chairman and Secretary are authorized to execute the same electronically and this instrument shall serve as confirmation of the signatures on the application.

PASSED AND APPROVED by the City Transit Trust this 25th day of March 2025.

STANLEY BOOKER, CHAIRMAN

ATTEST:

DONALYNN BLAZEK-SCHERLER, SECRETARY

APPROVED as to form this _____ day of _____, 2025.

TIMOTHY WILSON, INTERIM CITY ATTORNEY

Item Title:

Consider approving a resolution authorizing the filing and execution of a grant for federal assistance under Section 5339 Federal Transit Administration for Federal Fiscal Year 2024 appropriated funding, approving the application, and authorizing the Chairman and Secretary to execute the same.

Initiator: Christine James, Director

Information Source: Ryan Landers

Background:

LATS has prepared a grant application in the amount of \$162,329 for the construction of the LATS downtown transfer Center using Federal Fiscal Year 2024 appropriated funding. The local share for this grant is \$40,582, which is projected to be in the City of Lawton’s Capital Improvement Program (CIP) in FY 25-26. The application will be filed and reviewed electronically.

The Grants for Buses and Bus Facilities Competitive Program (49 U.S.C. 5339(b)) makes federal resources available to states and direct recipients to replace, rehabilitate and purchase buses and related equipment and to construct bus-related facilities, including technological changes or innovations to modify low or no emission vehicles or facilities. Funding is provided through formula allocations and competitive grants.

Eligible applicants for the Buses and Bus Facilities Program include designated recipients that allocate funds to fixed-route bus operators, states (including territories and Washington D.C.) or local governmental entities that operate fixed route bus service, and Indian tribes. Eligible subrecipients include all otherwise eligible applicants and also private nonprofit organizations engaged in public transportation.

The federal share of eligible capital costs is 80 percent of the net capital project cost, unless the grant recipient requests a lower percentage

Correlation to the True North Statement:

Citizens will benefit from an indoor transit center with restrooms.

Exhibit:

Resolution No. 2025-_____

Key Issues:

Execution of this grant does not commit the City of Lawton to spending the funds outlined in this agenda. FTA only requires you to have the local match at the time it draws down the federal share to pay eligible costs.

Funding Source:

FTA \$162,329 and CIP \$40,582

Staff Recommended Council Action:

Approve Resolution No. 2025- authorizing the filing of a grant for federal assistance under Section 5339 Federal Transit Administration for Federal Fiscal Year 2024 appropriated funding, approving the application execution and authorizing the Chairman and Secretary to execute the same.

ATTACHMENTS:

1. 5339 Grant resolution fy 24

RESOLUTION NO. 25-_____

A RESOLUTION AUTHORIZING THE FILING OF A GRANT FOR FEDERAL ASSISTANCE UNDER SECTION 5339, FEDERAL TRANSIT ADMINISTRATION, APPROVING THE APPLICATION FOR PART OF FTA FEDERAL FISCAL YEAR 2024 APPROPRIATED FUNDING AND AUTHORIZING THE CHAIRMAN AND SECRETARY TO EXECUTE APPROVAL OF THE SAME.

WHEREAS, the City Transit Trust is the designated recipient of Urbanized Area Formula Program assistance authorized by 49 U.S.C. Section 5307 Federal Transit Administration (FTA) grants to provide financial assistance in the operation of a public transportation system in the Lawton-Fort Sill community, and

WHEREAS, the City Transit Trust desires to obtain financial assistance from the Federal Transit Administration for the purpose of continuing its public transit system, and

WHEREAS, the City Transit Trust has approved Master Agreement (FTA MA 31) for FTA Federal Fiscal Year 2024, which provides that any entity receiving federal financial assistance must abide by applicable Federal laws and regulations; and

WHEREAS, the City Transit Trust has been previously provided copies of the approved budget and cost allocation plan for this grant.

NOW, THEREFORE, BE IT RESOLVED by the City Transit Trust of Lawton, Oklahoma that:

SECTION 1. The grant application for part of FTA Federal Fiscal Year 2024 appropriated funding under Section 5339, Federal Transit Administration is approved, and the Chairman and Secretary are authorized to execute the same electronically and this instrument shall serve as confirmation of the signatures on the application.

PASSED AND APPROVED by the City Transit Trust this 25th day of March 2025.

STANLEY BOOKER, CHAIRMAN

ATTEST:

DONALYNN BLAZEK-SCHERLER, SECRETARY

APPROVED as to form this _____ day of _____, 2025.

TIMOTHY WILSON, INTERIM CITY ATTORNEY

Item Title:

Consider receiving a presentation from Wendel WD Architecture, accepting the thirty percent design for Phase 1 of the Transfer Center, and directing staff to move forward on attaining contract for remaining design and construction bid documents, allowing for floor amendments if necessary.

Initiator: Christine James, Director

Information Source: Ryan Landers, LATS General Manager

Background:

On September 12, 2023, the City Transit Trust approved the scope and fee contract submitted by Wendel WD Architecture. Since that approval, the majority of the project timeline has been dedicated to completing the NEPA (National Environmental Policy Act) environmental review and conducting a geotechnical investigation, both of which were essential prerequisites prior to commencing construction with federal funding.

As the project has evolved, the scope of work has been adjusted to divide it into three distinct phases. The first phase focuses on the development of the transfer center at the designated site, located on a parcel of land between SE B Ave and SE D Ave along SE Larance St. The design and renderings for this phase were approved by the Transfer Center Site Selection Committee on February 5, 2025.

Wendel is now prepared to present the 30% design drawings, cost estimates, and accompanying report to the City Transit Trust for review and approval.

Correlation to the True North Statement:

Exhibit:

- Transit Transfer Center Drawings
- Transit Transfer Center Report
- Transit Transfer Center Presentation

Key Issues:

Funding Source:

FTA 80% and 2016 & 2019 CIP 20%

Staff Recommended Council Action:

Receive a presentation from Wendel WD Architecture, accept the thirty percent design for Phase 1 of the Transfer Center, and direct staff to move forward on attaining contract for remaining design and construction bid documents, allowing for floor amendments as necessary.

ATTACHMENTS:

1. Transit Transfer Center Drawings
2. Transit Transfer Center Report
3. Transit Transfer Center Presentation



DRAWING INDEX	
SHEET NUMBER	SHEET NAME
GENERAL	
G000	COVERSHEET
G001	TITLES & SYMBOLS
ARCHITECTURE	
AD101	DEMO PLANS EVIDENCE BUILDING
A001	PHASED SITE PLANS
A002	SITE PERSPECTIVES AND AXONS
A003	CODE COMPLIANCE NOTES AND LIFE SAFETY PLAN
A100	FIRST FLOOR PLAN
A150	OVERALL ROOF PLAN
A301	BUILDING ELEVATIONS
A800	WINDOW ELEVATIONS

30% SCHEMATIC DESIGN

LAWTON AREA TRANSIT SYSTEM

TRANSIT CENTER, MAINTENANCE & OPERATIONS FACILITY

100 SW RAILROAD ST
 LAWTON, OKLAHOMA, 73501

30% SCHEMATIC DESIGN
 MARCH 07, 2025



Centerpointe Corporate Park
 375 Essjay Road, Suite 200
 Williamsville, NY 14221
 www.wendelcompanies.com
 p.716.688.0766 f.877.293.6335

Wendel Project No. 629001

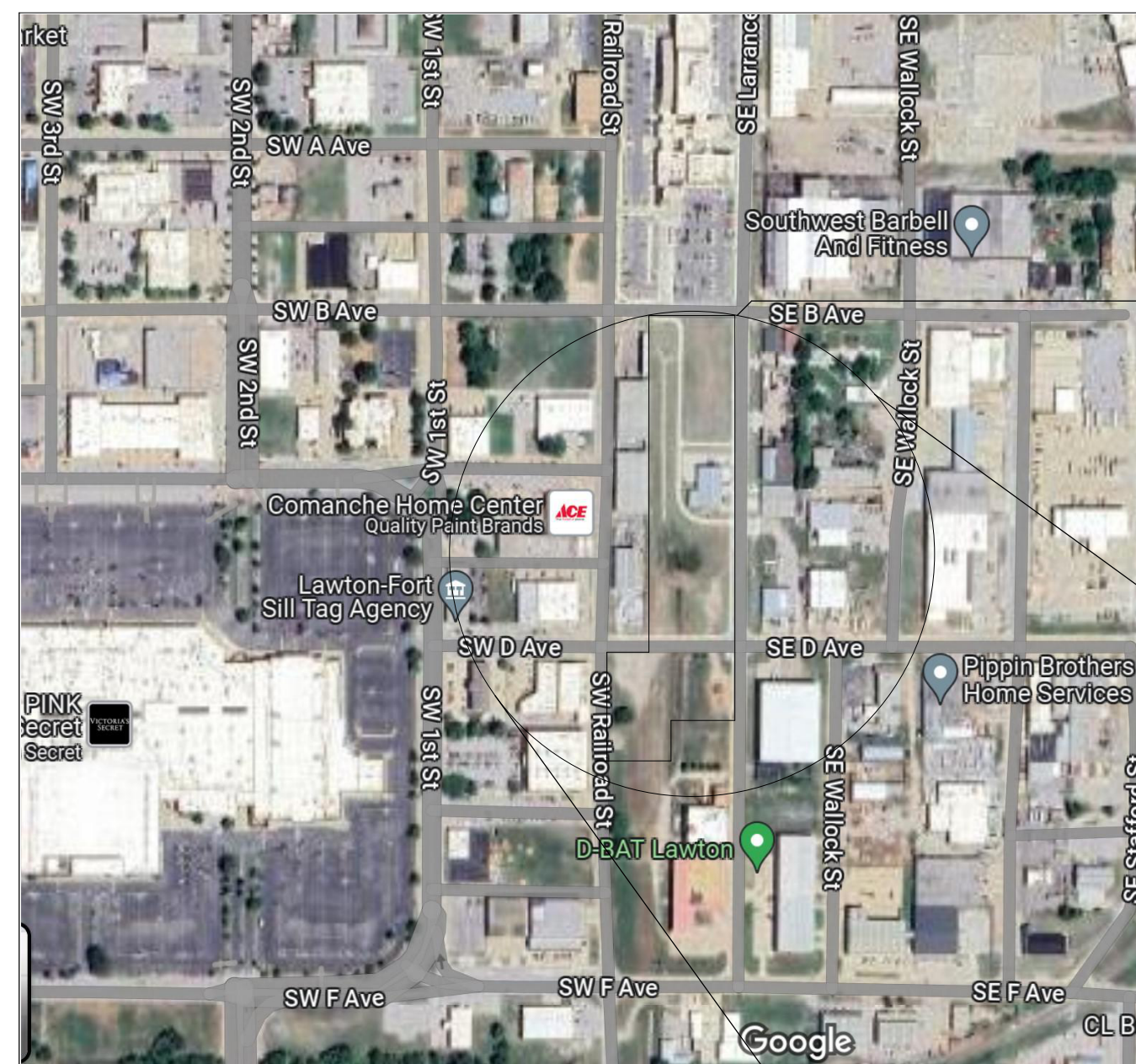

SITE



PROJECT LOCATION



PROJECT TEAM

A&M Engineering and Environmental Services, Inc.
 10010 E. 16TH STREET
 TULSA, OK 74128-4813
 T. 918-465-6375

BUILDING CODE INFORMATION:

PROJECT LOCATION: LAWTON CITY TRANSIT MULTIMODAL CENTER
215 SE LARRANCE STREET
LAWTON, OKLAHOMA 73501

PROJECT SCOPE:
CURRENTLY LATS DOES NOT HAVE A TRANSIT CENTER BUILDING. A BUS ONLY LANE ON SW B AVENUE PROVIDES ACCESS TO SEVERAL ON STREET TRANSIT BAYS. LATS IS RENOVATING THE EXISTING EVIDENCE BUILDING OWNED BY THE CITY OF LAWTON ON 215 SE LARRANCE STREET BETWEEN SOUTHEAST B AVENUE AND SOUTHEAST D AVENUE. THE NEW FACILITY WILL RENOVATE INTERIOR OF THE EVIDENCE BUILDING FOR USE AS A TRANSIT FACILITY. THIS WILL BE A LEVEL II ALTERATION ALONG WITH AN OCCUPANCY CLASSIFICATION CHANGE. ADDITIONALLY, THE EXTERIOR OF THE BUILDING WILL BE RE-GLAZED TO HAVE A BRICK EXTERIOR WHICH INVOLVES THE STIFFENING OF THE BUILDING AND NEW BRICK LEDGES. A SEPARATE, TRANSIT CANOPY WILL BE CONSTRUCTED TO PROVIDE WEATHER COVERAGE FOR PASSENGERS.

BUILDING AND FIRE CODES:
2021 OKLAHOMA STATE BUILDING CODE:

- 2018 INTERNATIONAL BUILDING CODE (IBC) WITH OKLAHOMA AMENDMENTS
- 2018 INTERNATIONAL EXISTING BUILDING CODE (IEBC) WITH OKLAHOMA AMENDMENTS
- 2018 INTERNATIONAL FIRE CODE (IFC)
- 2018 INTERNATIONAL PLUMBING CODE (IPC) WITH OKLAHOMA AMENDMENTS
- 2018 INTERNATIONAL MECHANICAL CODE (IMC) WITH OKLAHOMA AMENDMENTS
- 2018 FUEL GAS CODE
- 2009 INTERNATIONAL ENERGY CONSERVATION CODE (IECC)
- 2020 NFPA 70, NATIONAL ELECTRIC CODE (NEC)
- 2009 ICC/ANSI A117.1 ACCESSIBLE AND USABLE BUILDINGS AND FACILITIES
- 2010 DEPARTMENT OF JUSTICE ACCESSIBILITY STANDARDS
- 2014 ICC 500 STORM SHELTER CODE

OCCUPANCY CLASSIFICATION:

- SINGLE OCCUPANCY
- MIXED OCCUPANCY
 - B, BUSINESS
 - A, ASSEMBLY (A3)
 - S1, STORAGE
- INCIDENTAL OCCUPANCY
- ACCESSORY OCCUPANCY
 - A, ASSEMBLY

TYPE OF CONSTRUCTION: TYPE IIB
FULLY SPRINKLERED: YES

BUILDING HEIGHT AND AREA:
NOTE: THE BUILDING WAS REVIEWED AS MIXED USE NON SEPARATED. THE FOLLOWING IS BASED ON THE MOST RESTRICTIVE.

BUILDING AREA SUMMARY	ALLOWABLE AREA (SF)	PROVIDED AREA (SF)
<i>TRANSIT CENTER</i>		
B, BUSINESS	69,000	1,752
S-1, STORAGE	52,500	2,315
A-3, ASSEMBLY	28,500	564
AREA FACTOR INCREASE DUE TO FRONTAGE*	0.75	
TOTAL ALLOWABLE AREA	35,625	6,147
BUILDING SUMMARY (TRANSIT CENTER)		
	ALLOWED	PROVIDED
GRADE PLANE	-	-
BUILDING HEIGHT	75'	21' - 6"
NUMBER OF STORIES	3	1

OCCUPANCY	WITHOUT SPRINKLER SYSTEM (feet)	WITH SPRINKLER SYSTEM (feet)
A, E, F-1, M, R, S-1	200	250
I-1	Not Permitted	250
B	200	300
F-2, S-2, U	300	400

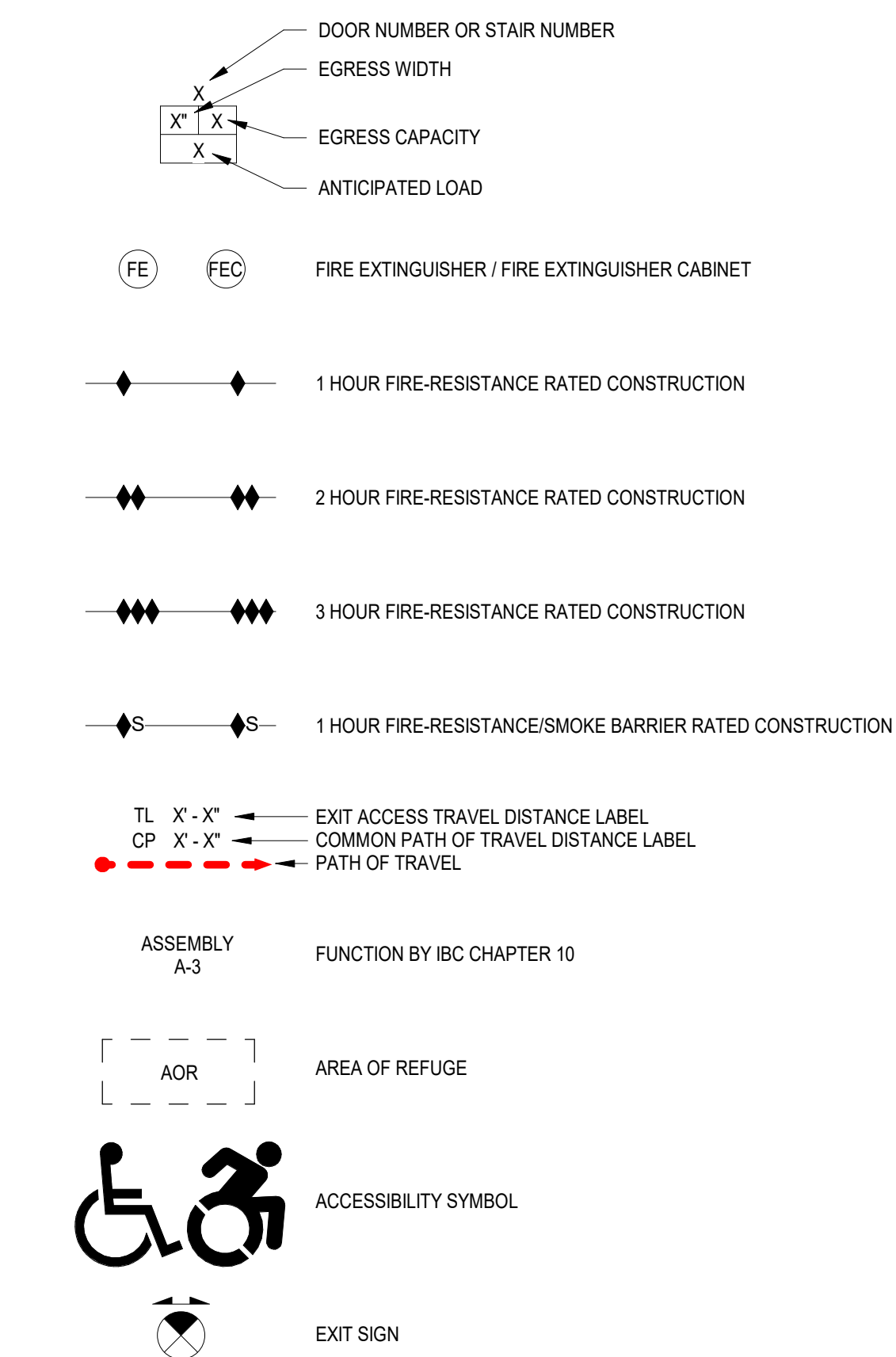

CODE SYMBOLS
SCALE: 1/8" = 1'-0"

CODE REFERENCES:

EXISTING BUILDING CODE REFERENCES

- 301.3 Alteration, Addition or Change of Occupancy**
The alteration, addition or change of occupancy of all existing buildings shall comply with one of the methods listed in Section 301.3.1, 301.3.2 or 301.3.3 as selected by the applicant. Sections 301.3.1 through 301.3.3 shall not be applied in combination with each other.
- 301.3.1 Prescriptive Compliance Method**
Alterations, additions and changes of occupancy complying with Chapter 5 of this code in buildings complying with the International Fire Code shall be considered in compliance with the provisions of this code.
- 305.3 Extent of Application**
An alteration of an existing facility shall not impose a requirement for greater accessibility than that which would be required for new construction. Alterations shall not reduce or have the effect of reducing accessibility of a facility or portion of a facility.
- 305.4.2 Complete Change of Occupancy**
Where an entire building undergoes a change of occupancy, it shall comply with Section 305.4.1 and shall have all of the following accessible features:
 - Not fewer than one accessible building entrance.
 - Not fewer than one accessible route from an accessible building entrance to primary function areas.
 - Signage complying with Section 1111 of the International Building Code.
 - Accessible parking, where parking is being provided.
 - Not fewer than one accessible passenger loading zone, where loading zones are provided.
 - Not fewer than one accessible route connecting accessible parking and accessible passenger loading zones to an accessible entrance.
- 503.1 General**
Except as provided by Section 302.4, 302.5 or this section, alterations to any building or structure shall comply with the requirements of the International Building Code® for new construction. Alterations shall be such that the existing building or structure is not less complying with the provisions of the International Building Code® than the existing building or the structure was prior to the alteration.

[BS] 503.3 Existing Structural Elements Carrying Gravity Load
Any existing gravity load-carrying structural element for which an alteration causes an increase in design dead, live or snow load, including snow drift effects, of more than 5 percent shall be replaced or altered as needed to carry the gravity loads required by the International Building Code for new structures. Any existing gravity load-carrying structural element whose gravity load-carrying capacity is decreased as part of the alteration shall be shown to have the capacity to resist the applicable design dead, live and snow loads including snow drift effects required by the International Building Code for new structures.

506.1 Compliance
A change of occupancy shall not be made in any building unless that building is made to comply with the requirements of the International Building Code for the use or occupancy. Changes of occupancy in a building or portion thereof shall be such that the existing building is not less complying with the provisions of this code than the existing building or structure was prior to the change. Subject to the approval of the code official, changes of occupancy shall be permitted without complying with all of the requirements of this code for the new occupancy, provided that the new occupancy is less hazardous, based on life and fire risk, than the existing occupancy.

506.4.2 Snow and Wind Loads
Where a change of occupancy results in a structure being assigned to a higher risk category, the structure shall satisfy the requirements of Sections 1608 and 1609 of the International Building Code for the new risk category.

506.4.1 Live Loads
Structural elements carrying tributary live loads from an area with a change of occupancy shall satisfy the requirements of Section 1607 of the International Building Code. Design live loads for areas of new occupancy shall be based on Section 1607 of the International Building Code. Design live loads for other areas shall be permitted to use previously approved design live loads. Exception: Structural elements whose demand-capacity ratio considering the change of occupancy is not more than 5 percent greater than the demand-capacity ratio based on previously approved live loads need not comply with this section.

603.1 Scope
Level 2 alterations include the reconfiguration of space, the addition or elimination of any door or window, the reconfiguration or extension of any system, or the installation of any additional equipment.

801.3 Compliance
New construction elements, components, systems, and spaces shall comply with the requirements of the International Building Code. Exceptions:

- Where windows are added they are not required to comply with the light and ventilation requirements of the International Building Code.
- Newly installed electrical equipment shall comply with the requirements of Section 907.
- The length of dead-end corridors in newly constructed spaces shall only be required to comply with the provisions of Section 905.6.
- The minimum ceiling height of the newly created habitable and occupiable spaces and corridors shall be 7 feet (2134 mm).
- Where provided in below-grade transportation stations, existing and new escalators shall be permitted to have a clear width of less than 32 inches (815 mm).
- New structural members and connections shall be permitted to comply with alternative design criteria in accordance with Section 302.

803.2.2 Groups A, B, E, F-1, H, I, M, R-1, R-2, R-4, S-1 and S-2
In buildings with occupancies in Groups A, B, E, F-1, H, I, M, R-1, R-2, R-4, S-1 and S-2, work areas that have exits or corridors shared by more than one tenant or that have exits or corridors serving an occupant load greater than 50 shall be provided with automatic sprinkler protection where both of the following conditions occur:

- The work area is required to be provided with automatic sprinkler protection in accordance with the International Building Code as applicable to new construction.
- The work area exceeds 50 percent of the floor area.

BUILDING CODE REFERENCES
303.1.1 Small Buildings and Tenant Spaces
A building or tenant space used for assembly purposes with an occupant load of less than 50 persons shall be permitted to be classified as a Group B occupancy.

303.1.2 Small Assembly Spaces
The following rooms and spaces shall be permitted to be classified as Group B occupancies or as part of the assembly occupancy:

- A room or space used for assembly purposes with an occupant load of less than 50 persons and accessory to another occupancy shall be classified as a Group B occupancy or as part of that occupancy.
- A room or space used for assembly purposes that is less than 750 square feet (70 m²) in area and accessory to another occupancy shall be classified as a Group B occupancy or as part of that occupancy.

311.1.1 Accessory Storage Space
A room or space used for storage purposes that is accessory to another occupancy shall be classified as part of that occupancy.

502.1 Address Identification
New and existing buildings shall be provided with approved address identification. The address identification shall be legible and placed in a position that is visible from the street or road fronting the property. Address identification characters shall contrast with their background. Address numbers shall be Arabic numbers or alphabetical letters. Numbers shall not be spelled out. Each character shall be a minimum of 4 inches (102 mm) high with a minimum stroke width of 1/2 inch (12.7 mm). Where required by the fire code official, address identification shall be provided in additional approved locations to facilitate emergency response. Where access is by means of a private road and the building address cannot be viewed from a public way, a monument, pole, or other approved sign or means shall be used to identify the structure. Address identification shall be maintained.

506.2.2 Mixed-Occupancy, One-Story Buildings
The allowable area of a mixed-occupancy building with no more than one story above grade plane shall be determined in accordance with the applicable provisions of Section 506.1 based on Equation 5-1 for each applicable occupancy.

where: $A_u = A_r + (NS \times l_i)$
 A_u = Allowable Area (square feet)
 A_r = Tabular allowable area factor (NS, S13R, S13D or SM value, as applicable) in accordance with Table 506.2.
 NS = Tabular allowable area factor in accordance with Table 506.2 for a nonsprinklered building (regardless of whether the building is sprinklered).
 l_i = Area factor increase due to frontage (percent) as calculated in accordance with Section 506.3.

506.2.3 Allowable Building Area
The allowable area of the building shall be based on the applicable provisions of Section 506 for the main occupancy of the building. Aggregate accessory occupancies shall not occupy more than 10 percent of the floor area of the story in which they are located and shall not exceed the tabular values for nonsprinklered buildings in Table 506.2 for each such accessory occupancy.

508.3 Nonseparated Occupancies
Buildings or portions of buildings that comply with the provisions of this section shall be considered as nonseparated occupancies.
508.3.1 Occupancy Classification
Nonseparated occupancies shall be individually classified in accordance with Section 302.1. The requirements of this code shall apply to each portion of the building based on the occupancy classification of that space. In addition, the most restrictive provisions of Chapter 9 that apply to the nonseparated occupancies shall apply to the total nonseparated occupancy area.

1009.9.1 Travel Distance
The maximum travel distance from any accessible space to an area of refuge shall not exceed the exit access travel distance permitted for the occupancy in accordance with Section 1017.2.

1017.2 Limitations
Exit access travel distance shall not exceed the values given in Table 1017.2. Per Table 1017.2.

1029.8 Common Path of Egress Travel
The common path of egress travel shall not exceed 30 feet from any seat to a point where an occupant has a choice of two paths of egress travel to two exits. Exceptions:

- For areas serving less than 50 occupants, the common path of egress travel shall not exceed 75 feet.
- For smoke-protected or open-air assembly seating, the common path of egress travel shall not exceed 50 feet.

CODE OCCUPANCY SCHEDULE					
Name	Area	FUNCTION OF SPACE	CODE_OCCUPANT LOAD FACTOR_WNDL	CALCULATED OCCUPANCY LOAD	Level
ASSEMBLY, A-3					
WAITING ROOM	564 SF	ASSEMBLY - UNCONCENTRATED TABLES AND CHAIRS	15 SF	38	LEVEL 1
	564 SF			38	
BUSINESS, B					
TRANSIT CENTER	229 SF	BUSINESS AREAS	150 SF	2	LEVEL 1
TRANSIT CENTER	465 SF	BUSINESS AREAS	150 SF	4	LEVEL 1
TRANSIT CENTER	248 SF	BUSINESS AREAS	150 SF	2	LEVEL 1
BREAK ROOM	393 SF	ASSEMBLY - UNCONCENTRATED TABLES AND CHAIRS	15 SF	27	LEVEL 1
SUPPORT SPACES	417 SF	BUSINESS AREAS	150 SF	3	LEVEL 1
	1762 SF			38	
STORAGE, S-1 (MODERATE HAZARD STORAGE)					
PHASE 2 AREA (NO WORK)	3832 SF	STORAGE, S-1	300 SF	13	LEVEL 1
	3832 SF			13	
BUILDING TOTAL	6147 SF			89	

OCCUPANCY CLASSIFICATION

- A-3
- B
- S-1

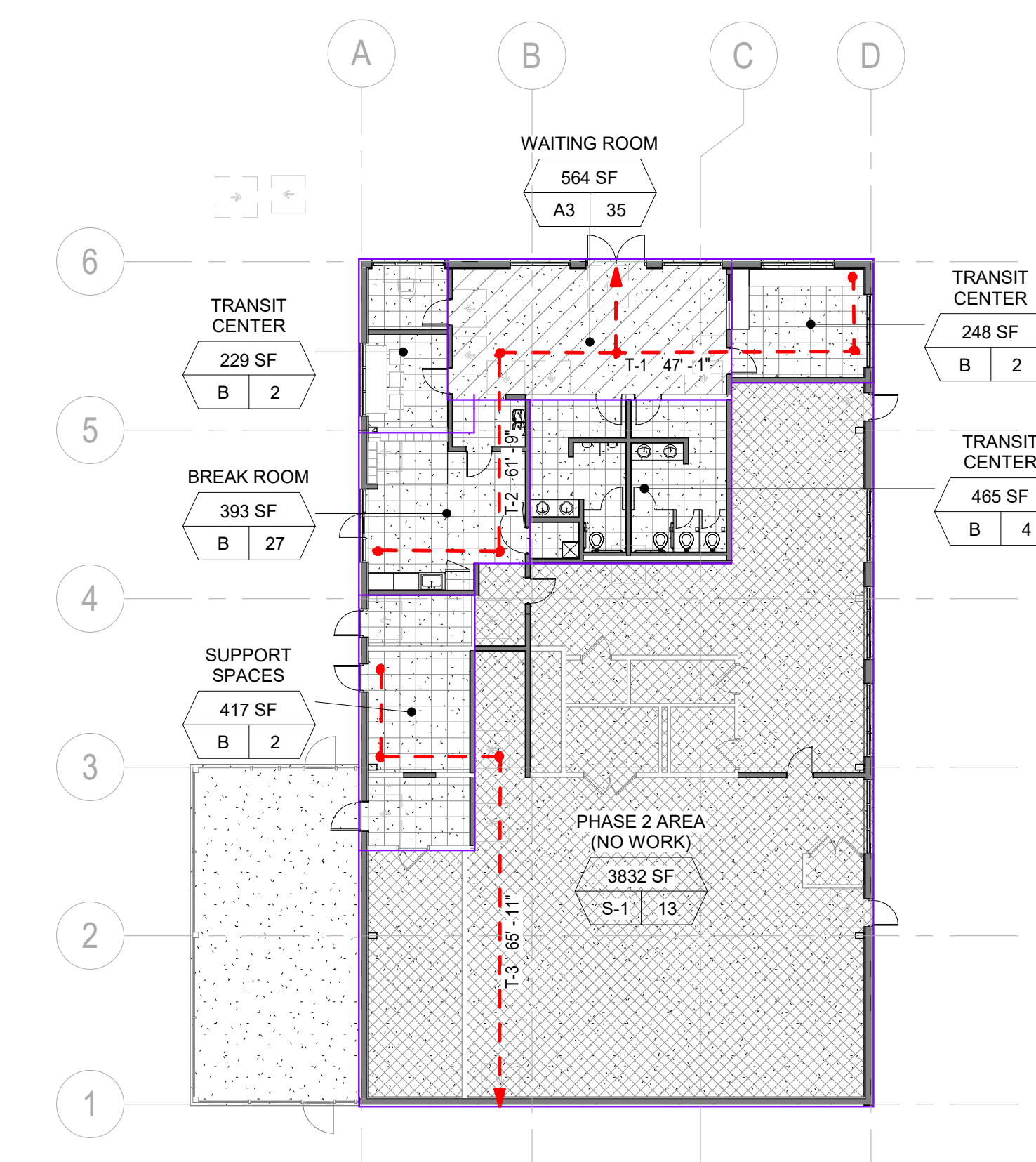

2 TRANSIT CENTER CODE PLAN
SCALE: 1/16" = 1'-0"



LAWTON AREA TRANSIT SYSTEM
TRANSIT CENTER, MAINTENANCE & OPERATIONS FACILITY
100 SW RAILROAD ST
LAWTON, OKLAHOMA, 73501

30% SCHEMATIC DESIGN



Centerpointe Corporate Park
375 Essjay Road, Suite 200
Williamsville, NY 14221
www.wendelcompanies.com
p:716.688.0766 f:877.293.6335

Wendel W.D. Architecture, Engineering, Surveying and Landscape Architecture P.C.

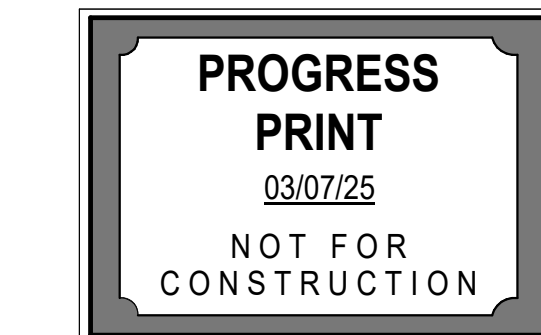

NOTE:
THIS DOCUMENT AND THE EXHIBITS INCORPORATED HEREIN, AS AN INSTRUMENT OF PROFESSIONAL SERVICE, IS THE PROPERTY OF THE ARCHITECT AND ENGINEER AND IS NOT TO BE REPRODUCED, COPIED, OR IN ANY MANNER FOR ANY OTHER PROJECT WITHOUT THE WRITTEN AUTHORIZATION OF THE ARCHITECT AND ENGINEER. UNAUTHORIZED REPRODUCTION OR ALTERATION OF ANY SURVEY DRAWING, DESIGN, SPECIFICATION, PLAN OR REPORT IS PROHIBITED IN ACCORDANCE WITH STATE LAW, CODE AND RULES.

NO.	REVISIONS	DATE

CODE COMPLIANCE NOTES AND LIFE SAFETY PLAN

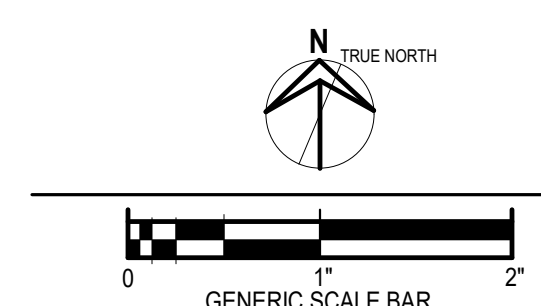

SCALE BAR SHOWN IS TWO INCHES ON THE ORIGINAL DRAWING.
DATE: 03/07/25
SCALE: As indicated
DWN: JMS CHK: JMS
PROJ. No: 629001
DWG. No:

A003

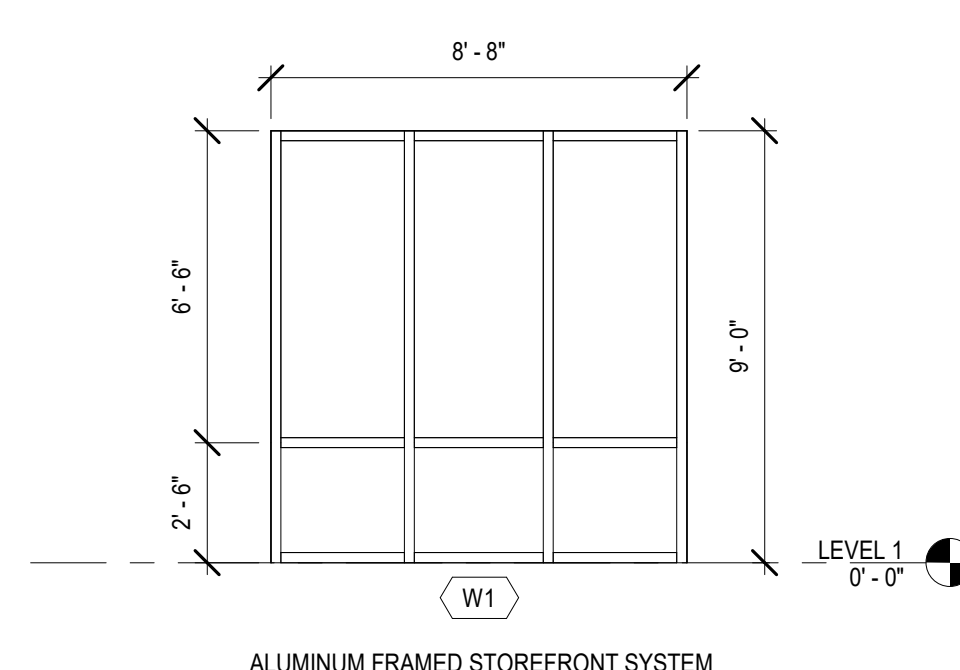

1 **W1**
 SCALE: 1/4" = 1'-0"

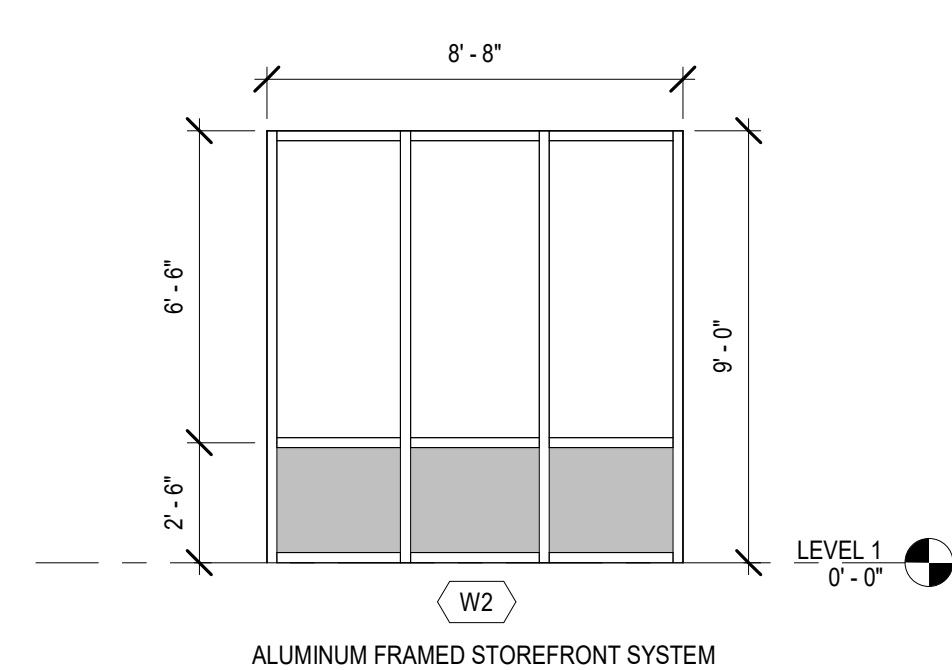

2 **W2**
 SCALE: 1/4" = 1'-0"

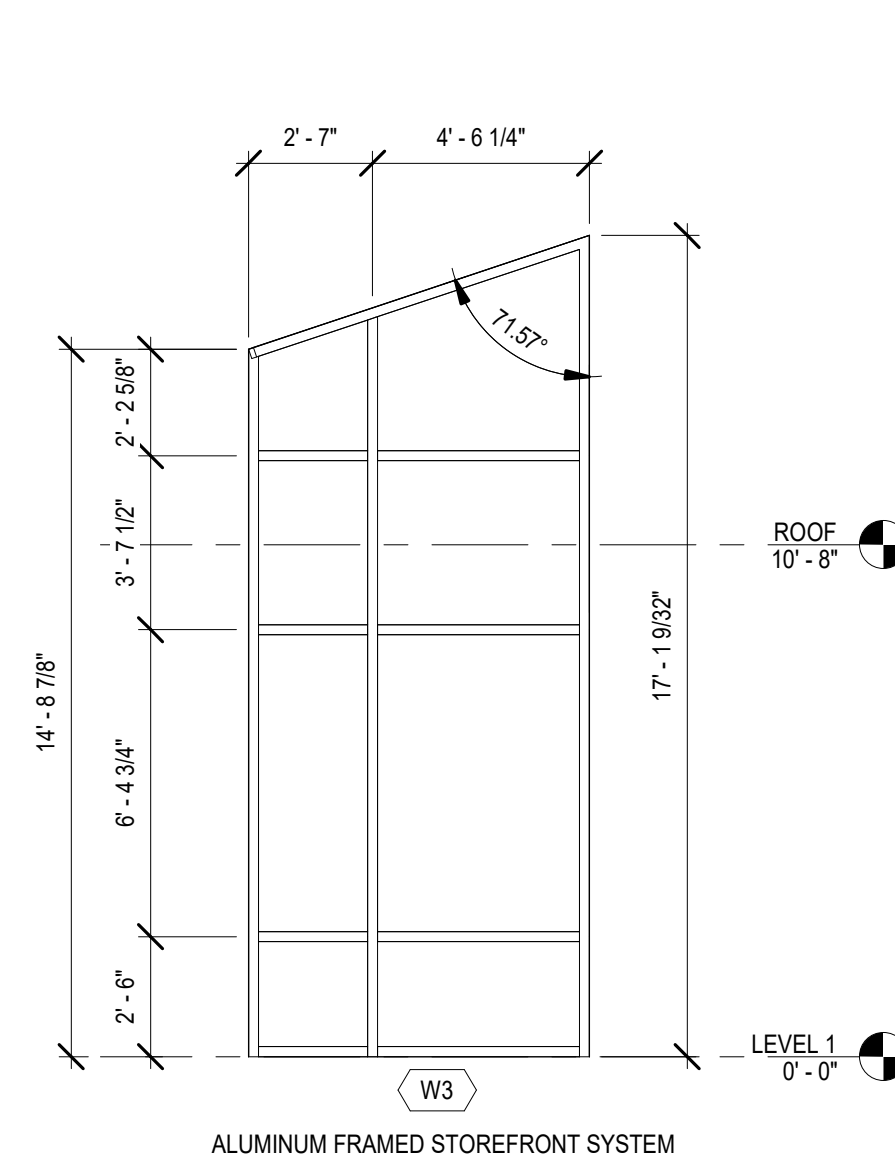

3 **W3**
 SCALE: 1/4" = 1'-0"

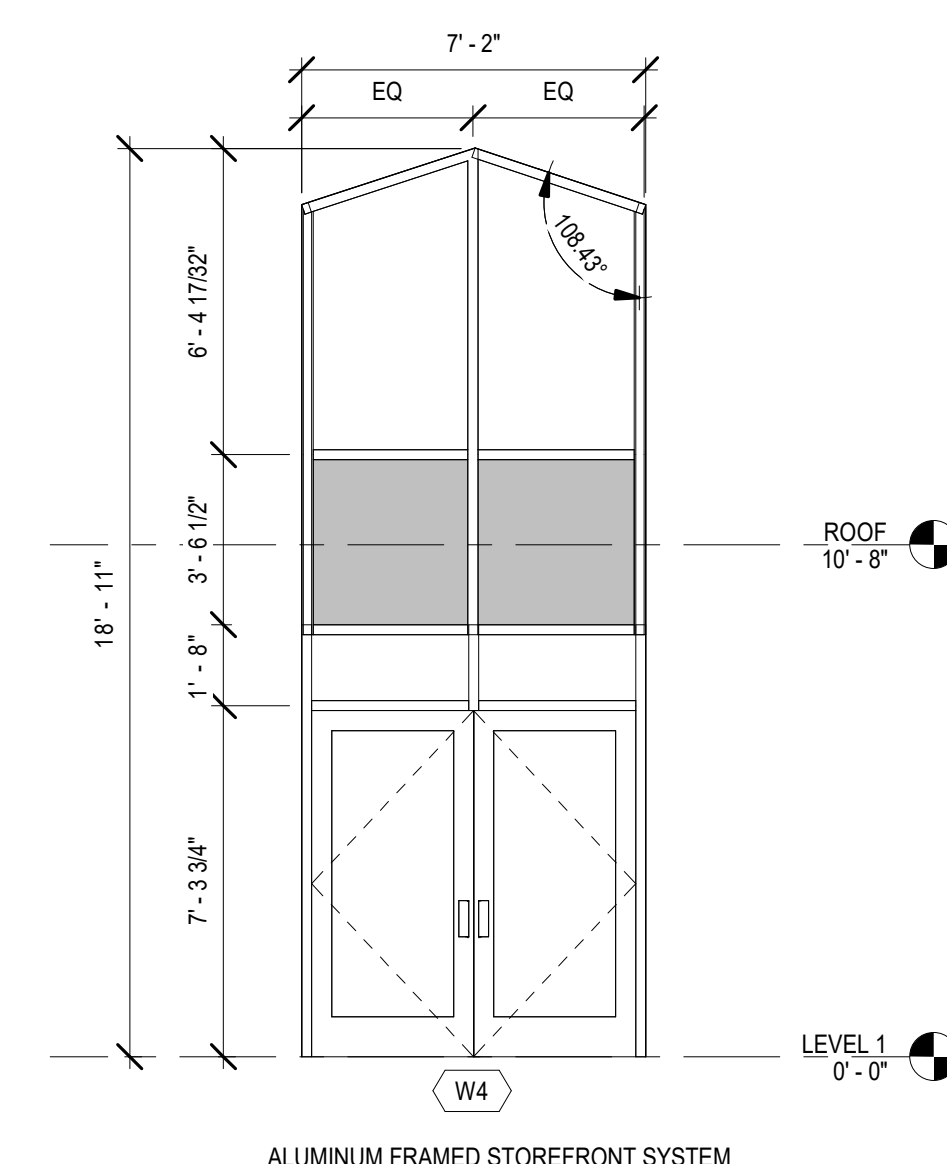

4 **W4**
 SCALE: 1/4" = 1'-0"

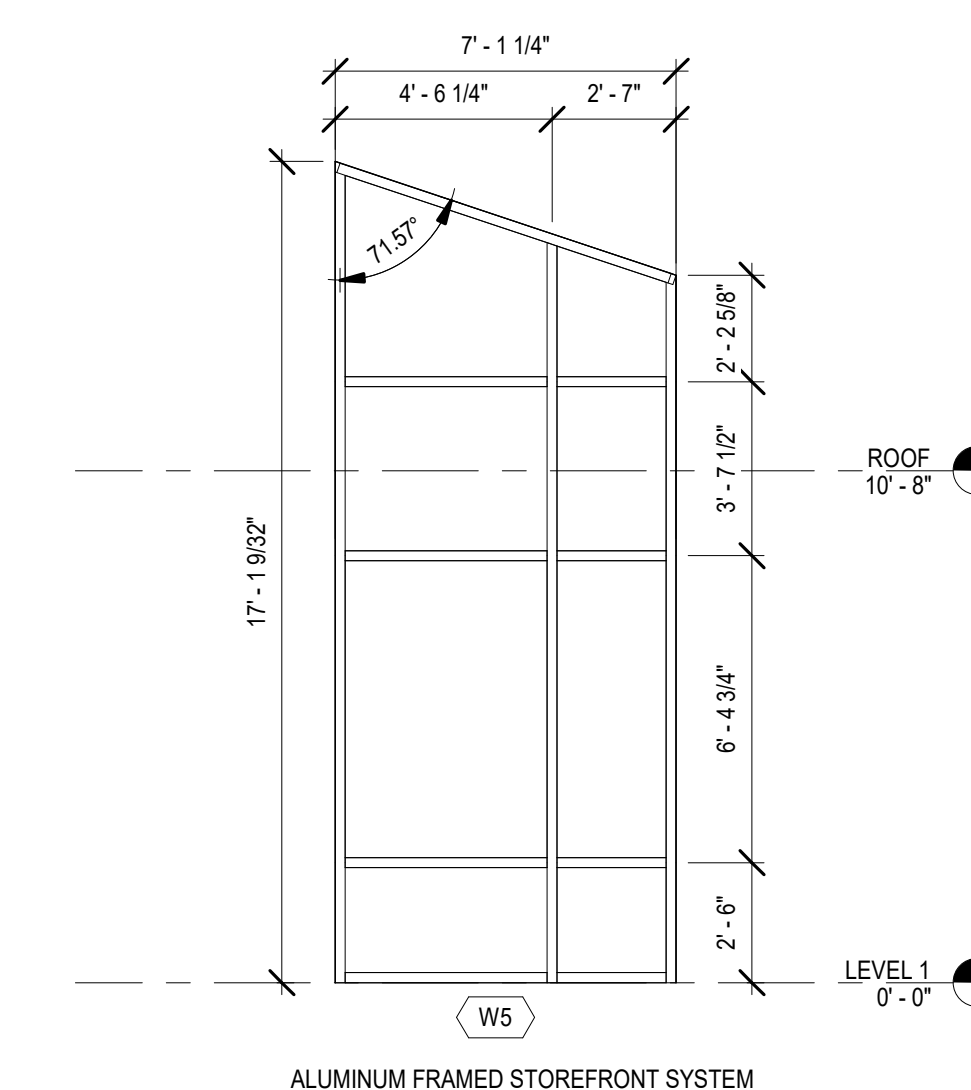

5 **W5**
 SCALE: 1/4" = 1'-0"

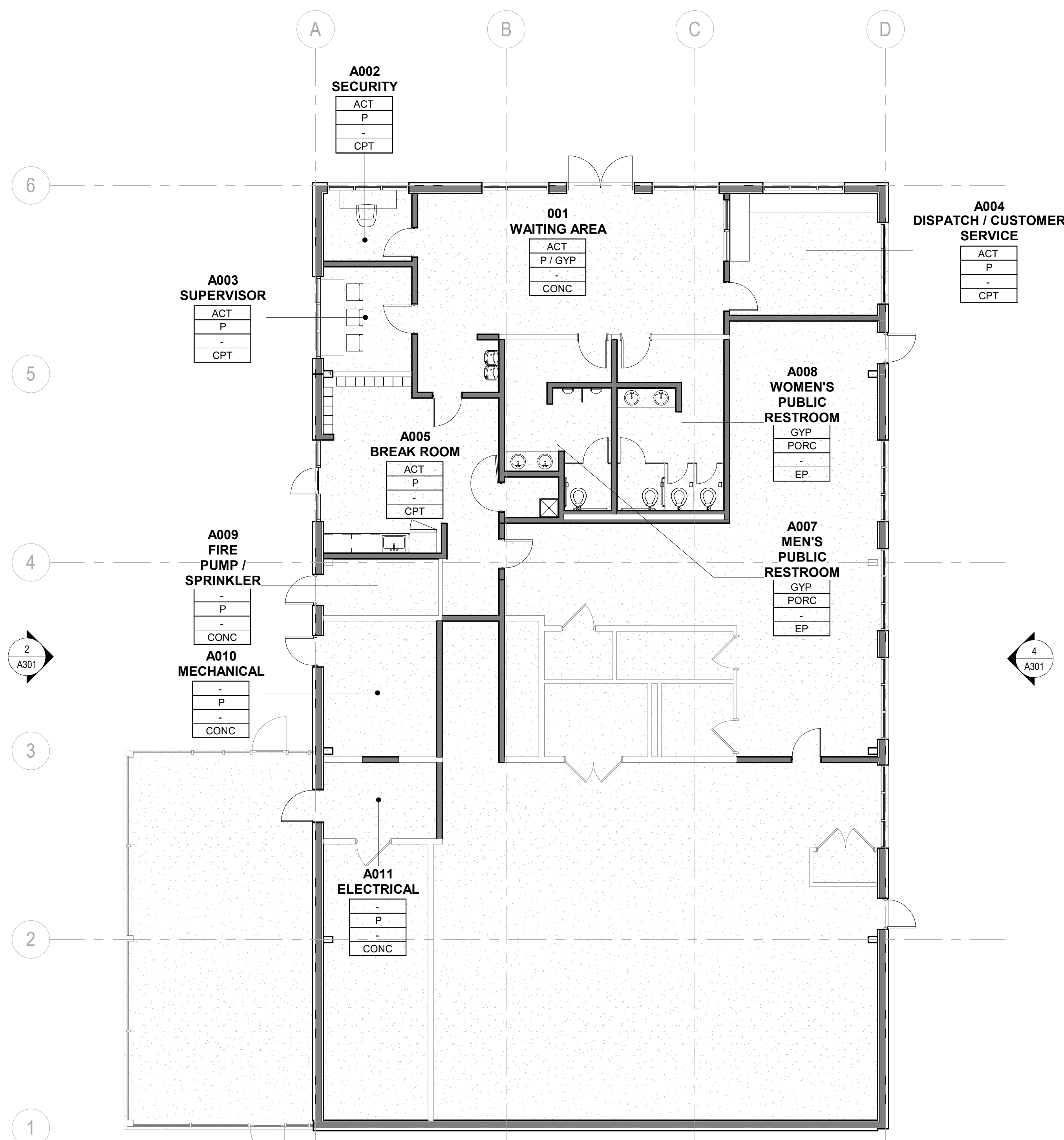

6 **FINISH PLAN**
 SCALE: 1/8" = 1'-0"

ROOM SCHEDULE			
ROOM NUMBER	ROOM NAME	Level	Area
NOTES:			
LEVEL 1			
001	WAITING AREA	LEVEL 1	538 SF
012	STORAGE	LEVEL 1	772 SF
015	UNisex RESTROOM	LEVEL 1	59 SF
A002	SECURITY	LEVEL 1	68 SF
A003	SUPERVISOR	LEVEL 1	108 SF
A004	DISPATCH / CUSTOMER SERVICE	LEVEL 1	204 SF
A005	BREAK ROOM	LEVEL 1	255 SF
A006	LOCKERS	LEVEL 1	57 SF
A007	MEN'S PUBLIC RESTROOM	LEVEL 1	172 SF
A008	WOMEN'S PUBLIC RESTROOM	LEVEL 1	200 SF
A009	FIRE PUMP / SPRINKLER	LEVEL 1	73 SF
A010	MECHANICAL	LEVEL 1	173 SF
A011	ELECTRICAL	LEVEL 1	97 SF
A013	CORRIDOR	LEVEL 1	797 SF
A014	JANITOR	LEVEL 1	25 SF

PROGRESS PRINT
 03/07/25
 NOT FOR CONSTRUCTION

NOTE:
 THIS DOCUMENT AND THE EXHIBITS INCORPORATED HEREIN, AS AN INSTRUMENT OF PROFESSIONAL SERVICE, IS THE PROPERTY OF THE ARCHITECT AND ENGINEER AND IS NOT TO BE REPRODUCED OR COPIED FOR ANY OTHER PROJECT WITHOUT THE WRITTEN AUTHORIZATION OF THE ARCHITECT AND ENGINEER. UNAUTHORIZED REPRODUCTION OR ANY SURVEY DRAWING, DESIGN, SPECIFICATION, PLAN OR REPORT IS PROHIBITED IN ACCORDANCE WITH STATE LAW, CODE AND RULES.

NO.	REVISIONS	DATE

WINDOW ELEVATIONS

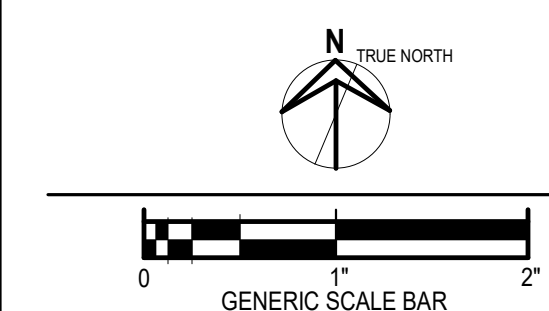

GENERIC SCALE BAR
 SCALE BAR SHOWN IS TWO INCHES ON THE ORIGINAL DRAWING
 IF NOT TWO INCHES ON THIS SHEET, ADJUST ACCORDINGLY
 DATE: 03/07/25
 SCALE: As indicated
 DWN: AJ
 PROJ. No: 629011
 DWG. No:

March 7, 2025

CITY OF LAWTON &
LAWTON AREA TRANSIT SYSTEM

MULTIMODAL TRANSFER CENTER SCHEMATIC DESIGN REPORT

Railroad Street
Lawton, OK
Wendel Project No. 629001



TITLE	SECTION
Introduction	1
Narrative	2
Opinion of Probable Construction Cost	3
Project Schedule	4
Appendix:	
A. Drawings	
B. Renderings	

Introduction

Introduction

The City of Lawton and Lawton Area Transit System (LATS) are planning to construct a new multimodal transfer center. The facility will be located on City-owned property located along Railroad Street in Lawton, OK adjacent to the recently completed public safety building. The current plan is to re-use and renovate a portion of the existing police evidence building on the site for this project. The existing bike and walking trail will also need to be maintained through the site.

The multimodal transfer center will include office space for transit dispatch, a ticket counter for the sale of bus passes for the Lawton Area Transit System as well as the sale of tickets for possible regional bus service, a passenger waiting area, dispatch/customer service, security office, and restrooms. The transfer center will serve as the hub for with parking for twelve buses. A canopy will cover passengers as they wait for and board the buses. The transfer center is designed to be able to be constructed and operated independently of the planned future phases. The second phase includes renovating the remainder of the police evidence building and adding an addition to have bus a maintenance facility. The third phase adds bus fueling, detailing and wash capabilities in another addition.

As part of the 30% design a survey of the site was completed to understand property lines, easements and topography. Geotechnical investigation has been completed and will inform the foundation and pavement design. Review of the preliminary stormwater calculations for the design and data from the public safety building show that managing stormwater will be a challenge for the project. The design team will work with the City to find solutions both on and off the project property.

NEPA has been completed during this phase of the project by A&M Engineering.

Upon the approval of this schematic design phase the design team will begin design development (60%). Anticipated milestones include design development (60%), construction documents (100%), bidding and construction administration as outlined in the schedule included in this report.

Narrative

Opinion of Probable Construction Cost

Narrative

Wendel worked with the City of Lawton and LATS during the concept phase to identify space needs and operational desires through a programming charrette. The stakeholders' goal was to modify the existing evidence building on site into a transit center with the opportunity for phased expansion. The Wendel team used this information to develop several conceptual site plans and through collaboration with the stakeholder team identified the desired site configuration. Throughout the conceptual design phase, the design team produced space blocking plans for discussion with LATS to refine acceptable adjacencies and travel paths. The stakeholder team directed the design team to utilize a historic rail station and the public safety building as points of inspiration for the three-dimensional design. Wendel created four iterations of the concept, exploring different options to modify the existing structure.

There is an adjacent lumberyard that occupies the western section of the property. Currently, a stormwater structure occupies the site as well. This structure along with an existing bike lane will be demolished as part of this project. The existing evidence building will be renovated to become the new transit center. Architecture sheet AD101 shows the demolition of the specific areas.

Transit Center Building

The transit center occupies the northernmost portion of the existing evidence building, facing the drop-off area. The waiting area occupies the main space when entering the building, with dispatch, customer service, security, supervisor, and public restrooms surrounding the open waiting space. An open ceiling and tall windows bring light and visibility to the buses. Security and dispatch are located on the NW and NE corners respectively. These areas also have visibility to the bus area.

The employee entrance is located on the west façade, providing direct access to the break room. Additionally, employees in the break area have direct access to the waiting area and the other office areas. The existing restroom in the evidence building will be reused for employees during phase one of renovations. Wendel has developed conceptual plans for phases two and three, to show the opportunity for expansion.

The existing metal cladding from the evidence building will be removed and the building will be re-skinned with face brick. Where possible, Wendel has utilized existing openings to create new windows throughout the building for efficiency with the existing metal building framing. These openings have Aluminum Storefront framing that sits on the existing slab to reduce the amount of additional steel framing that is required for the support of a more traditional punched window opening. This approach also allows for increased viewsheds to the exterior for both passengers and employees and will contribute to the daylighting of the space. The phase one project includes the renovation of the entire exterior façade creating new openings for future phases for efficiency with exterior renovation work. Where possible, Wendel has utilized existing openings to create new windows throughout the building for efficiency with the existing metal building framing. New cold formed metal framed walls with gypsum board will be constructed in between the existing

structural columns to provide a finished wall surface inside of the transit center and for additional support for the new brick cladding. The existing metal roof will be reused if possible, but the increase in the exterior wall thickness may require some modifications to the roof.

The interior of the transit center will be constructed with durable materials. The floor is proposed to be polished concrete and the walls where exposed to the public will be impact resistant gypsum board with paint. The office spaces will get carpet tile flooring, and the toilet rooms would get an industrial epoxy flooring system with porcelain tile walls. Ceilings will be a mix of ACT, gypsum clouds, and gypsum ceilings. Millwork will be laminate with quartz countertops for durability.

Bus Canopy

The project includes a 345' canopy for the bus drop off, designed with a single slope for efficiency and to match the sloped roofs of the project. Buses enter from the southern edge of the site off SE D Ave. and reach the bus drop-off on the northern portion of the site. They exit on SE B Ave. Supervisor parking is located to the west of the building with ADA spots are directly to the east.

The bus canopy will be constructed of architectural grade structural steel and dovetail long span deck. These elements will be coated with a high-performance coating system and an anti-graffiti coating. There are two scales of canopies, one is taller at the bus bays allowing for buses to pull in and passengers to be protected as they are exiting the bus while the other canopy is at a pedestrian scale providing protection while walking from the bus to the transit center building. Signage for the bus bays will be provided to provide clear indication of where the buses are to stop and where passengers will get on the bus. Benches will be provided under the canopy.

Phasing

The project is conceptually divided into three phases. Phase one includes the scope of work described above. Phase two as shown in the phasing plans includes additional offices required for operations and administration functions for LATS. This work would complete the interior renovation of the evidence building. Phase two also includes an addition of the maintenance portion of the project. This includes four maintenance bays, along with training and repair functions. Phase three includes the service lane addition.

Code

All buildings on the site will be type II noncombustible construction and be fully sprinklered. The transit center will be non-separated mixed-use occupancy. A full code review including more detailed occupancy counts per area are on the code sheet along with incorporated codes. This project will be following OK state code which is based upon the 2018 IBC family of codes.

Opinion of Probable Construction Cost

Project Name: Lawton O&M Multi-Model Facility
 Project Owner: Lawton Area Transit System
 Project Location: Lawton, Oklahoma
 Wendel Project
 Number: 629001
 Phase: SD
 Date: January 17, 2025
 GSF 6150



Division	Description	Total	Cost/SF	%
02 00 00	Existing Conditions	\$65,000	\$11	3%
03 00 00	Concrete	\$153,200	\$25	7%
04 00 00	Masonry	\$90,900	\$15	4%
05 00 00	Metals	\$527,670	\$86	24%
06 00 00	Wood, Plastics and Composites	\$16,155	\$3	1%
07 00 00	Thermal and Moisture Protection	\$164,425	\$27	7%
08 00 00	Openings	\$223,900	\$36	10%
09 00 00	Finishes	\$104,043	\$17	5%
10 00 00	Specialties	\$18,600	\$3	1%
13 00 00	Special Construction	\$32,000	\$5	1%
21 00 00	Fire Suppression	\$9,600	\$2	0%
22 00 00	Plumbing	\$52,800	\$9	2%
23 00 00	Heating, Ventilating and Air Conditioning	\$67,200	\$11	3%
26 00 00	Electrical	\$127,520	\$21	6%
27 00 00	Communications	\$46,700	\$8	2%
28 00 00	Electronic Safety and Security	\$25,150	\$4	1%
31 32 33	Earthwork, Exterior Improvements & Utilities	\$472,500	\$77	22%

Subtotal Construction Cost		\$2,197,363	\$357
10%	General Conditions	\$219,736	
10%	General Contractor OH&P	\$186,839	
5%	General Contractor OH&P on Sub-Contractor	\$16,449	
15%	Design Contingency	\$329,604	
15%	Construction Contingency	\$329,604	
6%	Escalation (to end of 2025)	\$131,842	
0%	CM Fee	\$0	
0%	Phasing	\$0	
Subtotal		\$3,411,437	
6%	Soft Costs (A/E Fees)	\$204,686	
Total		\$3,616,123	\$588
Range		\$3,435,317	\$3,796,929

Assumptions/Exclusions:
 Excludes any utility fees.
 Excludes the removal and replacement of unsuitable soils.
 Excludes any hazardous material removal or abatement.
 Escalation included to the end of 2025
 Excludes FFE

Opinion of Probable Construction Cost

Project Name: Lawton O&M Multi-Model Facility
 Project Owner: Lawton Area Transit System
 Project Location: Lawton, Oklahoma
 Wendel Project
 Number: 629001
 Phase: SD
 Date: January 17, 2025
 GSF 6150



DIVISION	DESCRIPTION	QTY	UNIT	UNIT COST	UNIT OF MEASURE	SUBTOTAL	DIVISION SUBTOTAL
02 00 00	Existing Conditions						\$65,000
	RX Exterior Metal siding	3,900	SF	\$ 12.00	E	\$ 46,800	
	RX Interior Partitions	1,020	SF	\$ 10.00	E	\$ 10,200	
	RX OHD	4	EA	\$ 2,000.00	E	\$ 8,000	
03 00 00	Concrete						\$153,200
	Canopy Sidewalk 6"	3,800	SF	\$ 14.00	E	\$ 53,200	
	Deep foundation	1	Allow	\$ 100,000.00	E	\$ 100,000	
04 00 00	Masonry						\$90,900
	Building Brick veneer	2,885	SF	\$ 25.00	E	\$ 72,125	
	8" CMU for pedestrian benches	100	SF	\$ 24.00	E	\$ 2,400	
	Pedestrian Bench Brick veneer, 1'-6" Tall	500	SF	\$ 25.00	E	\$ 12,500	
	Pedestrian bench Precast 10" Concrete Cap	155	LF	\$ 25.00	E	\$ 3,875	
05 00 00	Metals						\$527,670
	Structural Steel for Passenger Canopies	33	Ton	\$ 6,500.00	E	\$ 214,500	
	Structural Steel for Curtain Wall	2	Ton	\$ 6,500.00	E	\$ 13,000	
	Metal Decking 1-1/2"	6,480	SF	\$ 6.00	E	\$ 38,880	
	Structural Reinforcement for Building	37	Ton	\$ 6,500.00	E	\$ 240,500	
	Building CFMF	330	LF	\$ 63.00	E	\$ 20,790	
06 00 00	Wood, Plastics and Composites						\$16,155
	P-Lam Counter at Restrooms	20	LF	\$ 125.00	E	\$ 2,500	
	Wood Blocking	1	LS	\$ 5,000.00	E	\$ 5,000	
	Exterior wall sheathing	2,885	SF	\$ 3.00	E	\$ 8,655	
07 00 00	Thermal and Moisture Protection						\$164,425
	Passenger Canopy Roof System (Standing Seam)	6,000	SF	\$ 25.00	E	\$ 150,000	
	Building Insulation, Barrier, & Drywall	2,885	SF	\$ 5.00	E	\$ 14,425	
08 00 00	Openings						\$223,900
	Transaction Window	1	EA	\$ 10,000.00	E	\$ 10,000	
	Storefront	710	SF	\$ 165.00	E	\$ 117,150	
	Curtain Wall	295	SF	\$ 200.00	E	\$ 59,000	
	SF Double Doors, including hardware	1	EA	\$ 3,750.00	E	\$ 3,750	
	Interior WD DR/ HM FM/HW	8	EA	\$ 2,500.00	E	\$ 20,000	
	Exterior HM DR/HM FM/HW	5	EA	\$ 2,800.00	E	\$ 14,000	
09 00 00	Finishes						\$104,043
	Interior Partition	2,235	SF	\$ 12.00	E	\$ 26,820	
	Gyp Ceilings	400	SF	\$ 10.00	E	\$ 4,000	
	Paint	4,625	SF	\$ 2.50	E	\$ 11,563	
	ACT Ceilings	1,450	SF	\$ 8.00	E	\$ 11,600	
	Acoustic treatment (4 ACT Clouds in Waiting Room)	120	SF	\$ 50.00	E	\$ 6,000	
	Porcelain Tile at Restroom Walls	1,460	SF	\$ 16.00	E	\$ 23,360	
	Carpet Tile	950	SF	\$ 18.00	E	\$ 17,100	
	Epoxy Flooring	400	SF	\$ 9.00	E	\$ 3,600	
10 00 00	Specialties						\$18,600
	Bathroom Accessories (2 bathrooms)	2	EA	\$ 1,800.00	E	\$ 3,600	
	Canopy Signage	1	LS	\$ 10,000.00	E	\$ 10,000	
	Interior Signage	1	LS	\$ 5,000.00	E	\$ 5,000	
13 00 00	Special Construction						\$32,000
	Entry Canopies	160	SF	\$ 200.00	E	\$ 32,000	
21 00 00	Fire Suppression						\$9,600
	Sprinklers	2,400	SF	\$ 4.00	E	\$ 9,600	
22 00 00	Plumbing						\$52,800
	Plumbing Systems	2,400	EA	\$ 22.00	E	\$ 52,800	
23 00 00	Heating, Ventilating and Air Conditioning						\$67,200
	Mechanical Systems	2,400	SF	\$ 28.00	E	\$ 67,200	

26 00 00	Electrical							\$127,520
	Transit Center Electric	2,400	SF	\$ 32.00	E	\$	76,800	
	Canopy Electric	6,340	SF	\$ 8.00	E	\$	50,720	
27 00 00	Communications							\$46,700
	Communications	6,340	SF	\$ 5.00	E	\$	31,700	
	Canopy PA System	1	LS	\$ 15,000.00	E	\$	15,000	
28 00 00	Electronic Safety and Security							\$25,150
	Fire Alarm System	2,400	SF	\$ 3.50	E	\$	8,400	
	CCTV System (per camera)	6	EA	\$ 1,250.00	E	\$	7,500	
	Access Control (per door)	5	EA	\$ 1,850.00	E	\$	9,250	
31 32 33	Earthwork, Exterior Improvements & Utilities							\$472,500
	Earthwork, Exterior Improvements & Utilities	1.5	Acre	\$ 315,000.00	E	\$	472,500	
	Subtotal Construction Cost							\$2,197,363

Project Schedule



City of Lawton / LATS / Multimodal Transfer Center													
Multimodal Transfer Center													
3/7/2025													
Project Schedule													
		2025				2026				2027			
1	60% Design												
2	Client Review												
3	90% Design												
4	Client Review												
5	100% Design / Issue Bid Set												
6	Bidding / Contracting												
7	Permitting												
8	Construction Administration												
9	Close-Out												

LAWTON TRANSIT CENTER

30% DESIGN UPDATE



PHASED APPROACH

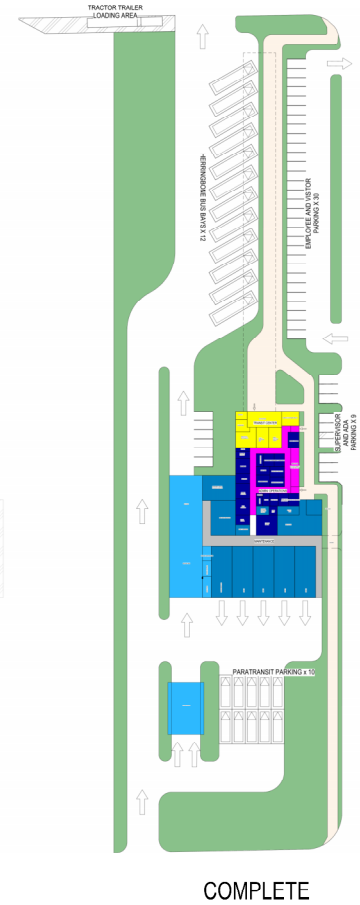
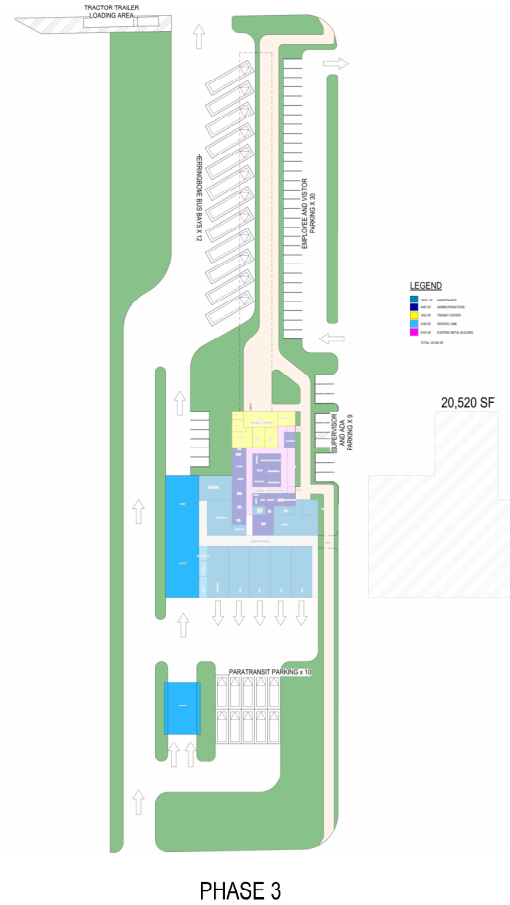
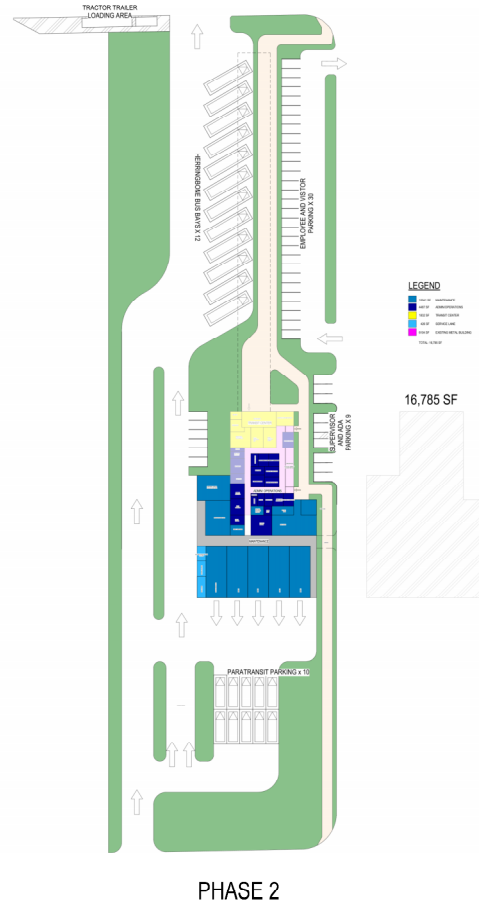
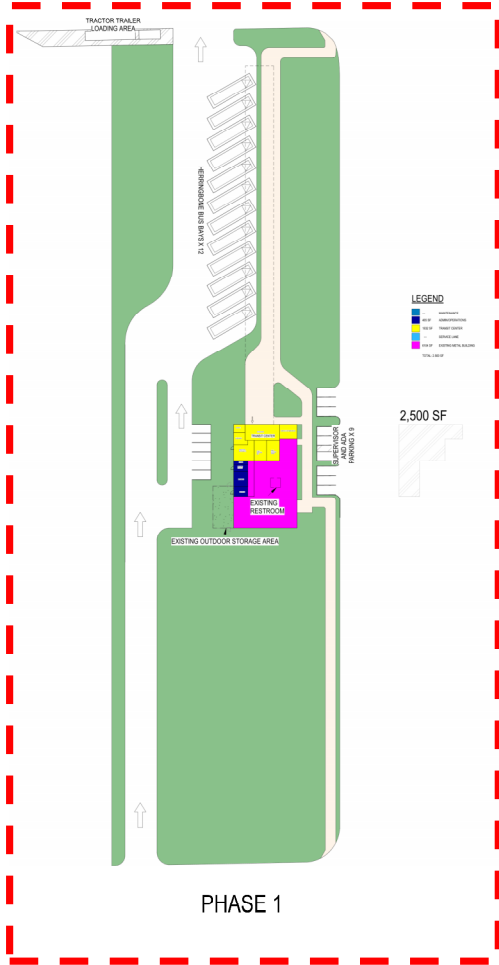

TRANSIT CENTER FLOOR PLAN

- ADMIN/ OPERATIONS
- TRANSIT CENTER
- EXISTING METAL BUILDING

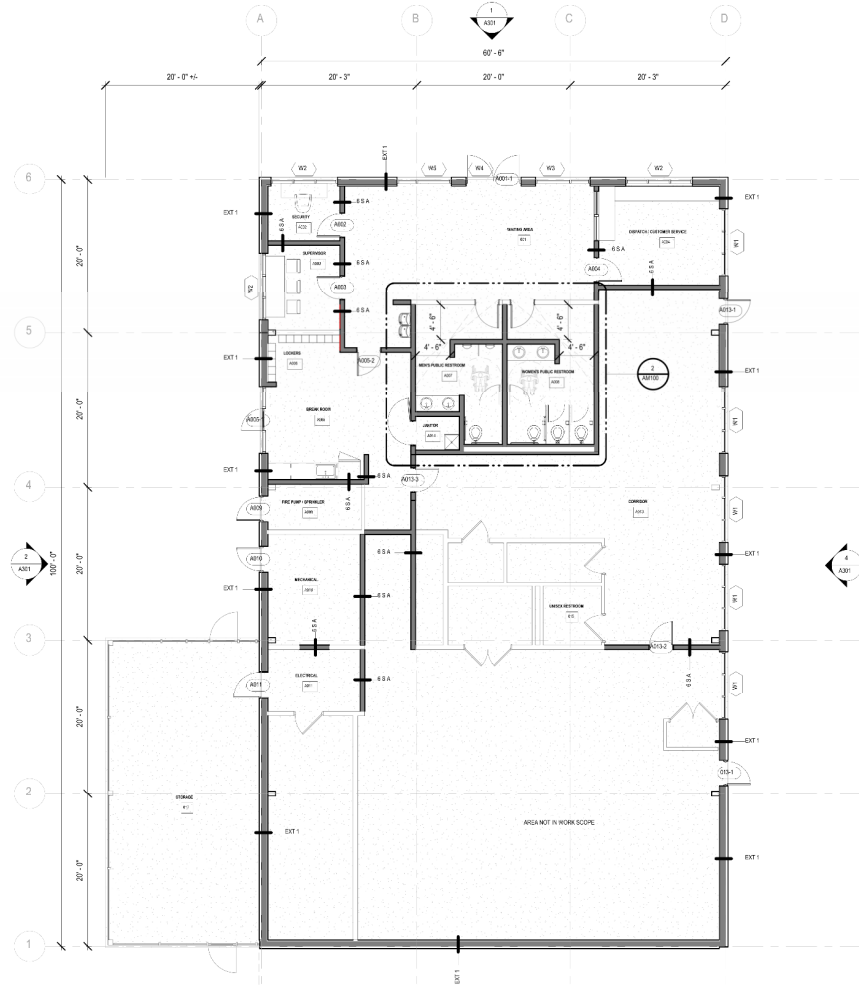
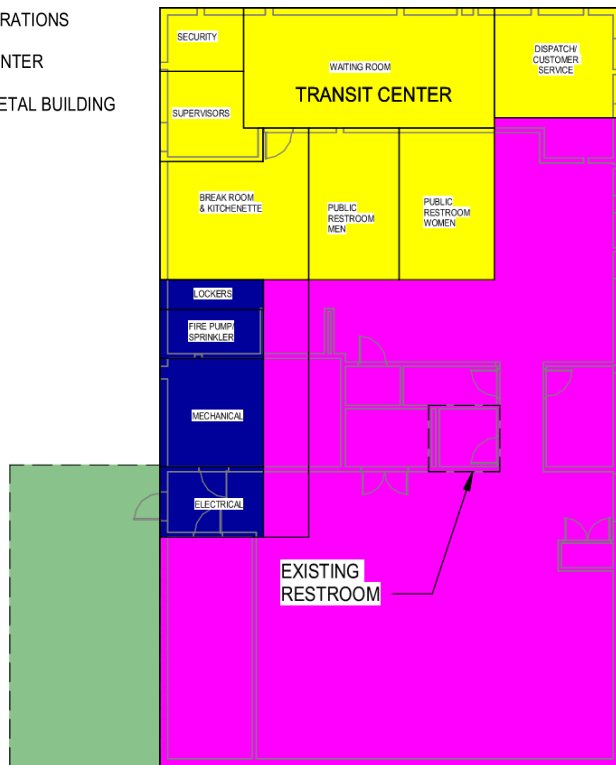

ELEVATIONS

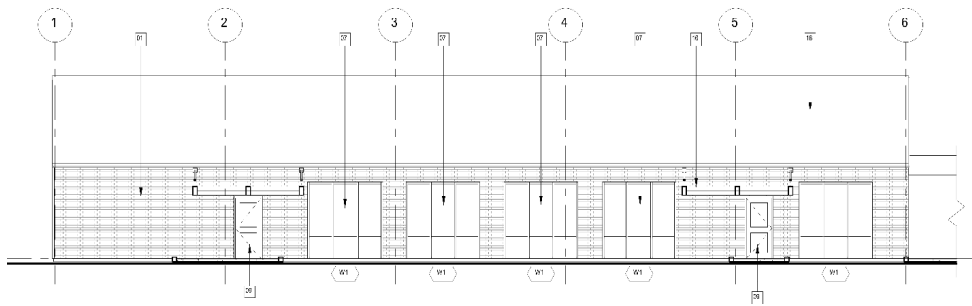

EAST ELEVATION

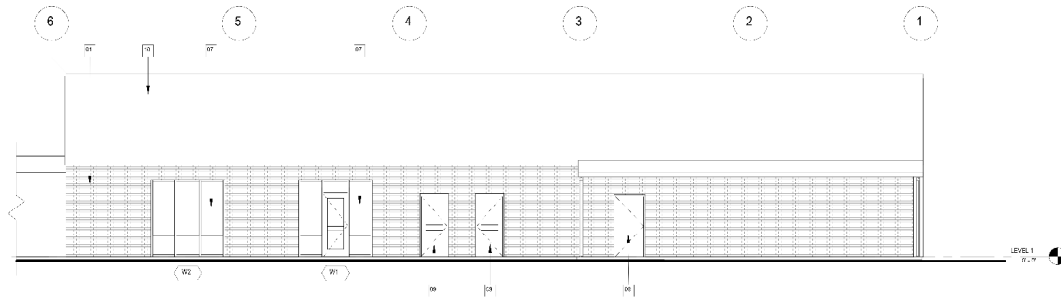

WEST ELEVATION

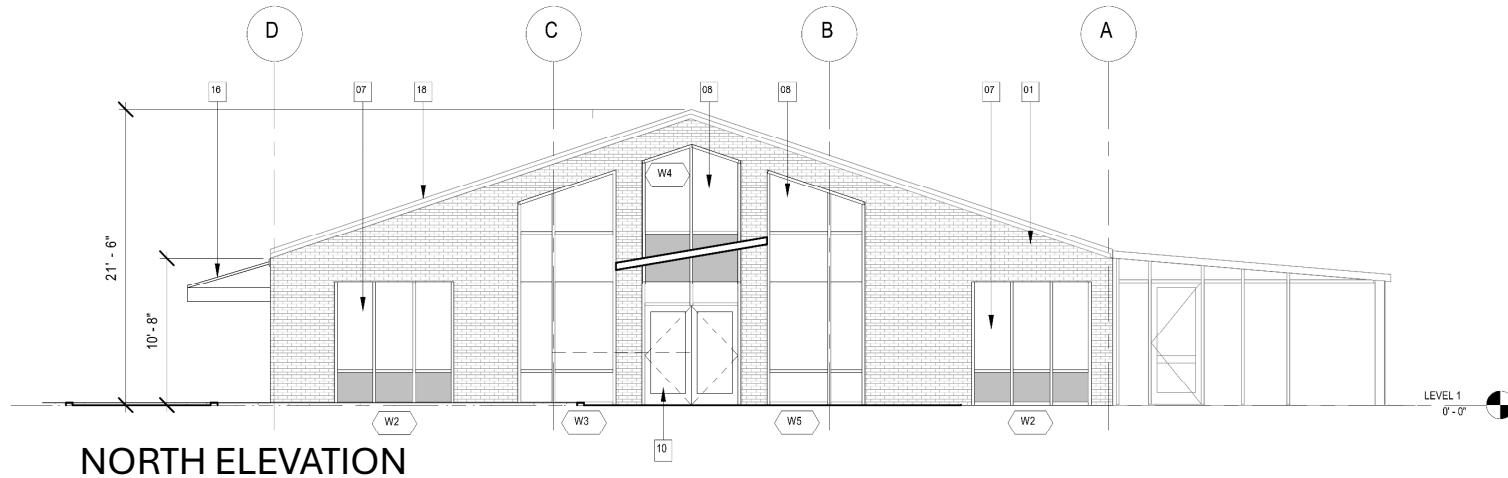

NORTH ELEVATION



TRANSIT CANOPY VIEWS

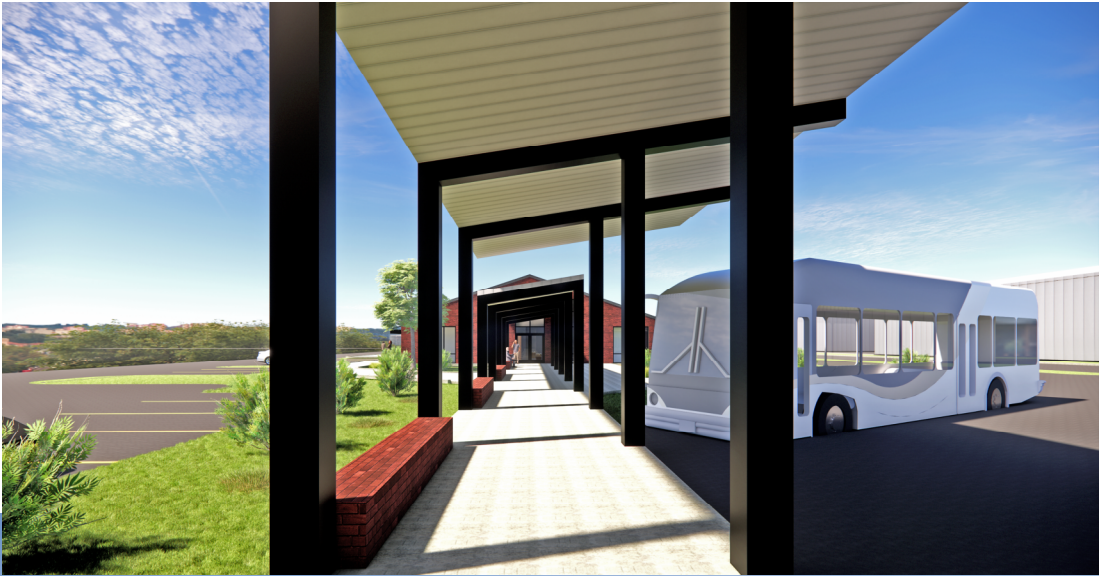

COST ESTIMATE

ESTIMATE IS \$3,616,123.00
BUT THERE IS A RANGE OF COST

TIMELINE INFLUENCES COST

BUILDING INVESTIGATION NEEDED
TO FINALIZE DESIGN APPROACH
AND COSTS. ESTIMATE HAS
ALLOWANCES FOR ASSUMPTIONS

Opinion of Probable Construction Cost

Project Name: Lawton O&M Multi-Model Facility
Project Owner: Lawton Area Transit System
Project Location: Lawton, Oklahoma
Wendel Project
Number: 629001
Phase: SD
Date: January 17, 2025
GSF: 6150



Division	Description	Total	Cost/SF	%
02 00 00	Existing Conditions	\$65,000	\$11	3%
03 00 00	Concrete	\$153,200	\$25	7%
04 00 00	Masonry	\$90,900	\$15	4%
05 00 00	Metals	\$527,670	\$86	24%
06 00 00	Wood, Plastics and Composites	\$16,155	\$3	1%
07 00 00	Thermal and Moisture Protection	\$164,425	\$27	7%
08 00 00	Openings	\$223,900	\$36	10%
09 00 00	Finishes	\$104,043	\$17	5%
10 00 00	Specialties	\$18,600	\$3	1%
13 00 00	Special Construction	\$32,000	\$5	1%
21 00 00	Fire Suppression	\$9,600	\$2	0%
22 00 00	Plumbing	\$52,800	\$9	2%
23 00 00	Heating, Ventilating and Air Conditioning	\$67,200	\$11	3%
26 00 00	Electrical	\$127,520	\$21	6%
27 00 00	Communications	\$46,700	\$8	2%
28 00 00	Electronic Safety and Security	\$25,150	\$4	1%
31 32 33	Earthwork, Exterior Improvements & Utilities	\$472,500	\$77	22%

Subtotal Construction Cost	\$2,197,363	\$357
10% General Conditions	\$219,736	
10% General Contractor OH&P	\$186,839	
5% General Contractor OH&P on Sub-Contractor	\$16,449	
15% Design Contingency	\$329,604	
15% Construction Contingency	\$329,604	
6% Escalation (to end of 2025)	\$131,842	
0% CM Fee	\$0	
0% Phasing	\$0	
Subtotal	\$3,411,437	
6% Soft Costs (A/E Fees)	\$204,686	
Total	\$3,616,123	\$588

Range	\$3,435,317	\$3,796,929
-------	-------------	-------------

Assumptions/Exclusions:
Excludes any utility fees.
Excludes the removal and replacement of unsuitable soils.
Excludes any hazardous material removal or abatement.
Escalation included to the end of 2025
Excludes FFE

PROJECT SCHEDULE

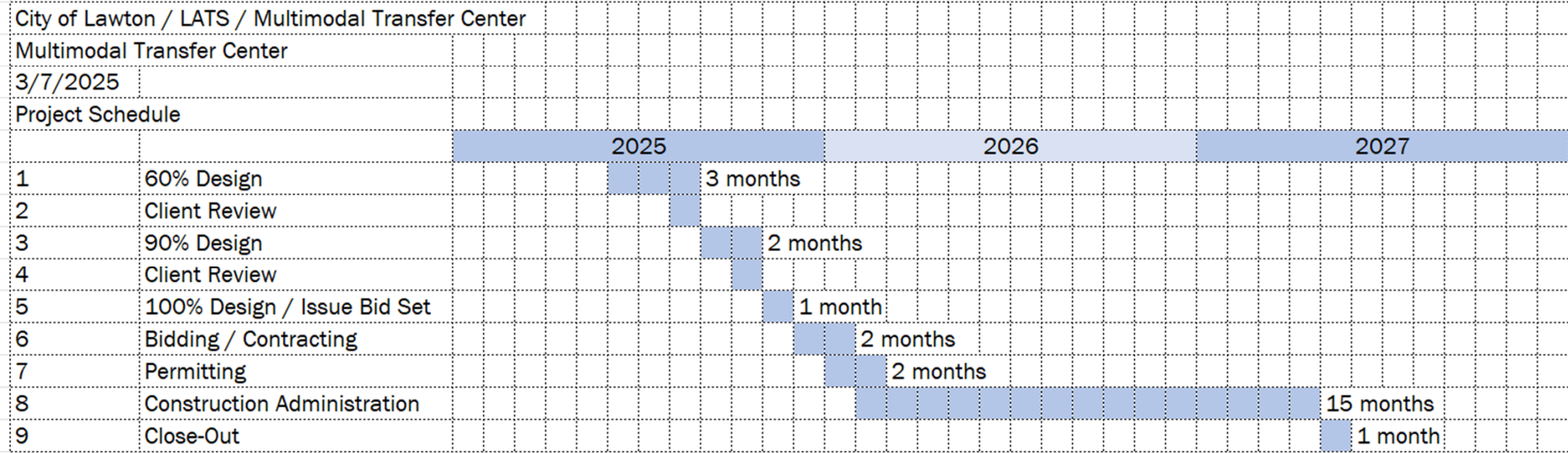

Item Title:

Hold a public hearing and consider approving a resolution updating the Title VI Program for the Lawton Area Transit System (LATS).

Initiator: Christine James, Director

Information Source: Ryan Landers

Background:

Title VI of the Civil Rights Act of 1964 prohibits discrimination on the basis of race, color, or national origin in programs and activities receiving Federal financial assistance (49 CFR 21 and Federal Transit Administration Circular 4702.1B). As a recipient of Federal grants, LATS must have a formal Title VI Program to handle any complaint of discrimination by its clients, employees or vendors. The current program expired on May 31, 2024. The plan has been accepted by the FTA and only needs to be accepted by the Transit Trust. This update is to reaffirm and approve the plan in compliance with 49 CFR § 21.9(b), and it serves as an update to the most recent census data.

Notice of the public hearing was published in *The Lawton Constitution* on February 15, 2025, and distributed and posted on all LATS vehicles, Transfer Center, Library, KSWO and social media.

Correlation to the True North Statement:

Exhibit:

Resolution 25-____
Title VI Program (on file in City Clerk’s office)

Key Issues:

None

Funding Source:

N/A

Staff Recommended Council Action:

Hold a public hearing and approve Resolution 25-____ and authorize the Chairman and Secretary to execute the same.

ATTACHMENTS:

- 1. Title VI 2025- resolution

RESOLUTION NO. 25-__

A RESOLUTION RELATED TO THE FEDERAL TRANSIT ADMINISTRATION APPROVING THE TITLE VI PROGRAM FOR THE TIME PERIOD OF FEDERAL FISCAL YEAR 2024 THROUGH FEDERAL FISCAL YEAR 2026 AND AUTHORIZING THE CHAIRMAN AND SECRETARY TO EXECUTE APPROVAL OF THE SAME.

WHEREAS, the City Transit Trust operates the Lawton Area Transit System; and

WHEREAS, the City Transit Trust obtains financial assistance from the Federal Transit Administration; and

WHEREAS, the City Transit Trust is required to abide by applicable Federal laws and regulations including a Title VI, Civil Rights Program as set out in 49 CFR and FTA Circular 4702.1B; and

WHEREAS, the purpose of the Title VI Program is to prohibit discrimination on the basis of race, color, or national origin in programs and activities.

NOW, THEREFORE, BE IT RESOLVED by the City Transit Trust, Lawton, Oklahoma, that:

SECTION 1. The updated Title VI Program is approved.

PASSED AND APPROVED by the City Transit Trust this 25th day of March 2025.

STANLEY BOOKER, CHAIRMAN

ATTEST:

DONALYNN BLAZEK-SCHERLER, SECRETARY

APPROVED as to form this _____ day of _____, 2025.

TIMOTHY WILSON, INTERIM CITY ATTORNEY